

Operating and Installation Instructions

Filter control system

RM-216 C.11

EasyLine

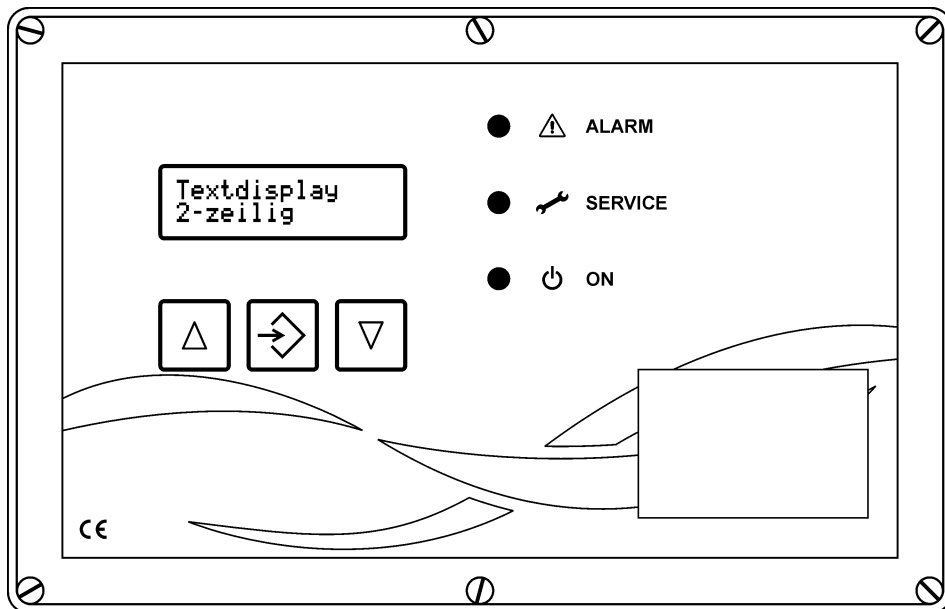

Table of Contents

1	Safety instructions	3
2	Equipment specification	3
3	Assembly	4
4	“Step by step” installation	4
5	“Step by step” settings.....	8
	5.1 Function when shipped.....	8
	5.2 Setting parameters	8
	5.3 Parameter list.....	10
6	Operating modes	11
	6.1 Test mode	11
	6.2 Δp -Mode (differential pressure controlled cleaning).....	11
	6.3 Down time cleaning modes	11
	6.4 Cleaning via start/stop input (external Δp switch).....	13
7	Troubleshooting.....	14
	7.1 Instructions for the replacement of the device fuse.....	15
	7.2 Cleaning the controller.....	15
	7.3 Manufacturing	16
8	Text messages on the display.....	17
9	Details on the equipment function	18
10	Glossary	19
11	Technical specifications	21

Regulations

2014/30/EU

2014/35/EU

Legend



Warning against physical and health hazards or damages to the product and other properties.



Attention, make absolutely sure to observe the notes in the documentation!



Important note



Identification of safety class II (protective insulation).
Complete double insulation or reinforced insulation.
The symbol is affixed to the device.



Identification of direct current (DC).

1 Safety instructions



The filter control system RM-216 C when connected to the mains poses an electrical hazard. Device failure, serious or even fatal injuries may occur as a result of improper installation of the connected equipment. Consequently, follow in particular the points set out below in addition to the general safety regulations for equipment in industrial electrical installations:

- Installation of the device may be carried out only by qualified experts, in accordance with the provisions of IEC 364, DIN VDE 0105 for electrical equipment.
- All applicable laws, conditions, orders and regulations governing the setting up of electrical equipment must be observed with respect to the installation site.
- Setting of equipment with degree of protection IP00 without covers, may only be performed by authorized expert staff, when disconnected, and whilst observing the local safety and accident prevention regulations.
- The RM-216 C may only be operated in the permitted operating area.
- Switch off the mains supply before replacing the filter control or any components connected to it. Otherwise the equipment may be damaged.

2 Equipment specification

The RM-216 C is used to control 24 V DC solenoid valves on filtering separators with compressed air pulse cleaning. After connecting the supply voltage, the filter control system functions fully automatically without further activation. With Δp mode switched on, the current differential pressure of the filter system is displayed on the text display. The cleaning is carried out depending on the differential pressure. The filter can be monitored via a Δp alarm switch point (Δp alarm).

The full scale output for the measured differential pressure can be set by the parameter 15 "dP range". The analog output signal is automatically adjusted to the set full scale output.

3 Assembly

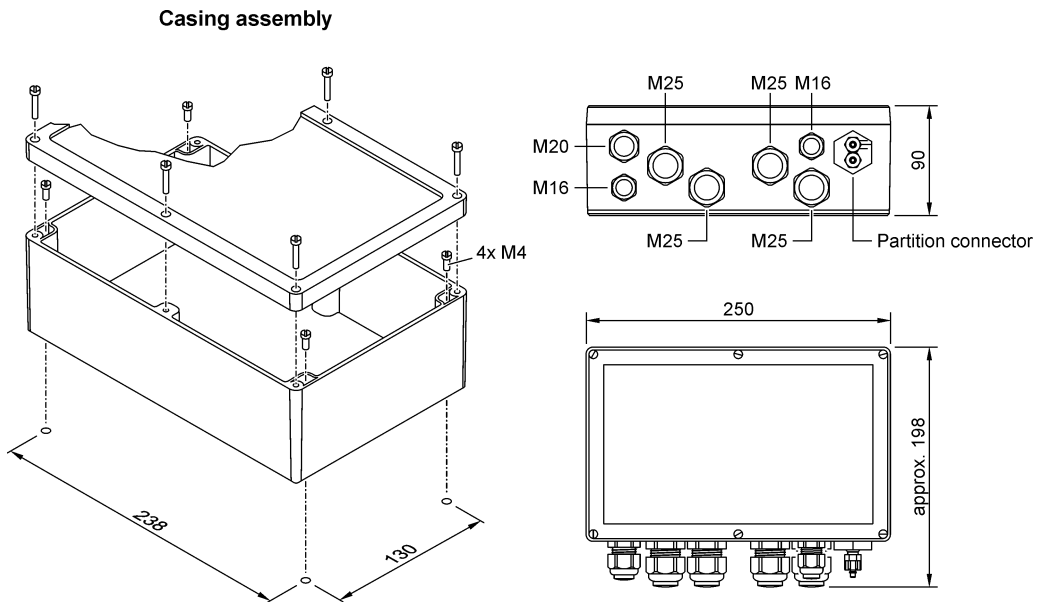

Wall-mounting of the filter controls is not permitted! The device may only be mounted to machine parts.

4 “Step by step” installation

1

Supply voltage connection

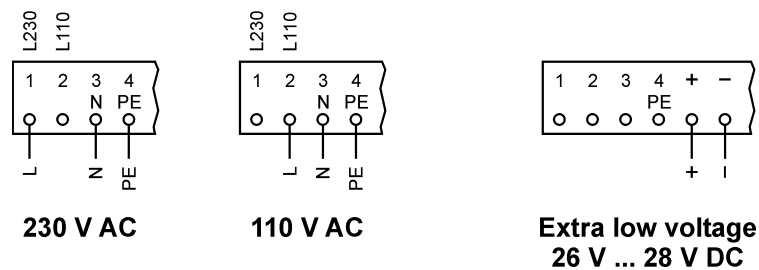

A UL class 2 power supply unit is recommended for the operation of the filter controller with extra low voltage.

2 Solenoid valve connection

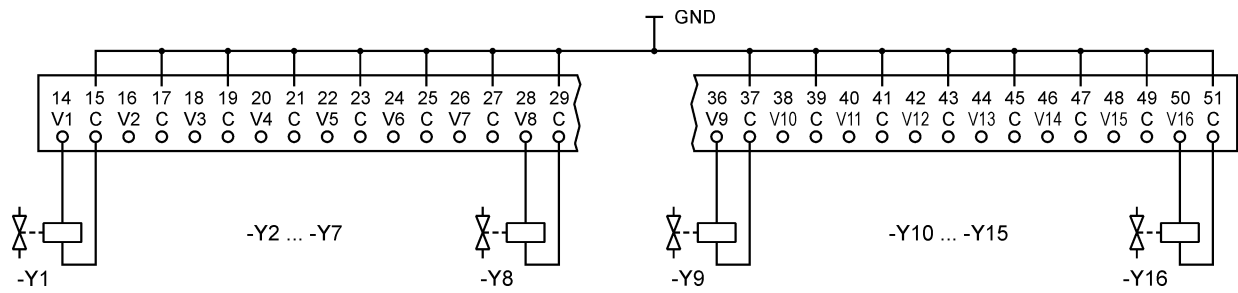

3 Connection of expansion modules RM-LV8 / RM-LV16

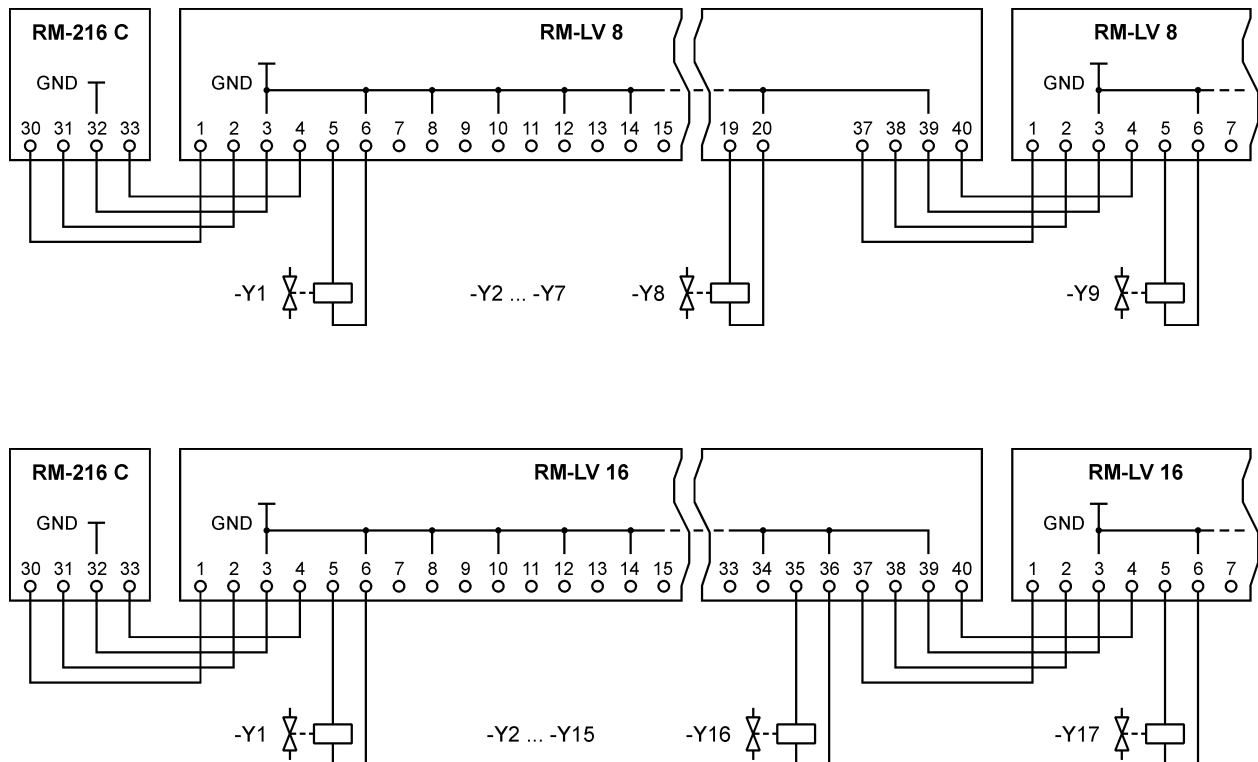

4 Other connections

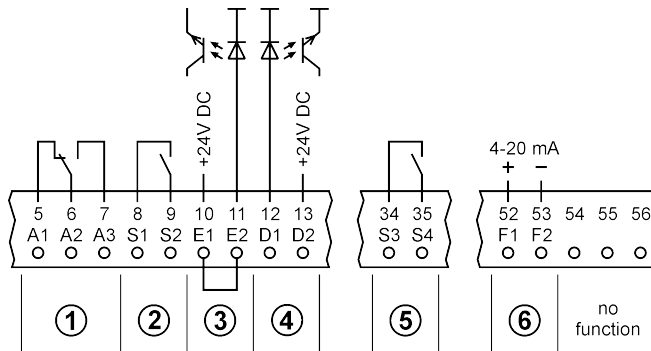

- ① "Common alarm" relay output
- ② Output to control an extractor element contactor
- ③ Down-time cleaning input (factory bridged)
- ④ Start/stop input (external Δp -switch)
- ⑤ Relay output " Δp MAX-Alarm"
- ⑥ Connections for Δp remote display (4-20-mA signal)



- A device (switch, power circuit breaker) must be located in the proximity of the filter controller RM-216 C, which enables the disconnection of all poles of the device from the mains voltage / supply voltage. The device (switch, power circuit breaker) has to be easy accessible for the user and to be marked as disconnecting device for the equipment.
- The wires and cables used for the connection of the controls must be suitable for an ambient temperature of up to 130 °C.
- Use shielded cable for all bus lines! The shielding must be connected unilaterally to the protective earthing (PE).
- Signal cables must not be laid parallel to power cables.
- Tighten all cable glands in use so the cables are properly enclosed and water cannot penetrate.
- Cable glands that are not in use must be closed or replaced by blind plugs.

5 Connecting differential pressure measurement cables

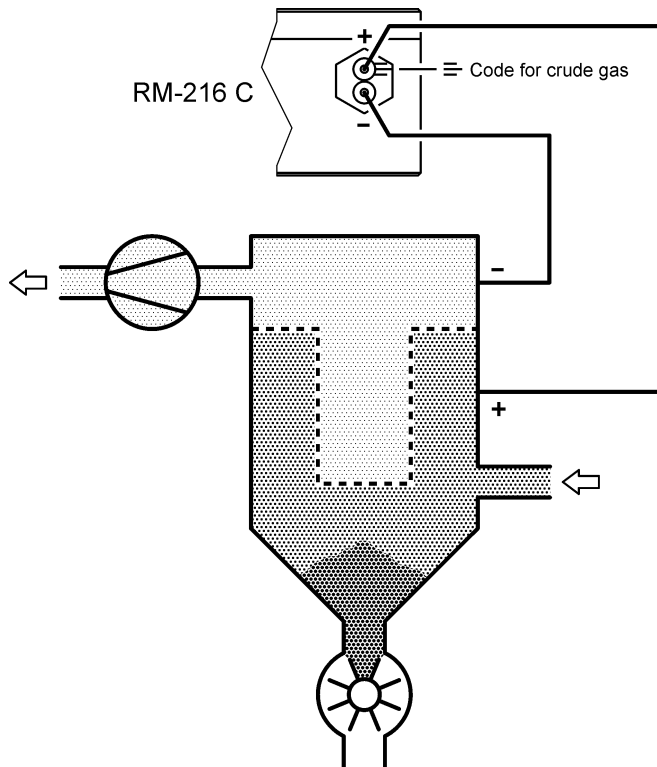

i

- Use hoses with 4 mm inner and 6 mm outer diameters.
- Connect the connection marked with 3 lines (black screw cap) to the crude gas side and the other connection (blue screw cap) to the pure gas side of the filter.

5 “Step by step” settings

5.1 Function when shipped

The down time cleaning input E1, E2 (terminals 10, 11) is bridged at the factory. The cleaning starts when the differential pressure Δp for the filter has reached the value Δp -MAX (factory setting: 1300 Pa). The solenoid valves are triggered in sequence. The RM-216 C automatically detects how many valves are connected. The cleaning process means that the differential pressure drops after a time. Cleaning stops when the differential pressure reaches the value Δp -MIN (factory setting: 700 Pa).

If another function is required or if additional functions are to be activated, the parameter setting of the RM-216 C must be changed. See also section 5.2.

5.2 Setting parameters

To set or check the parameters, proceed as follows:

- 1 Use the parameter list in section 5.3 to search for the parameters you want to change or check. On the RM-216 C, press buttons \blacktriangle and \blacktriangle simultaneously, for at least 3 seconds. The program then changes from operation mode to parameter selection mode. The parameter P00 “ Δp -MIN” is displayed on the text display at its set value.
- 2 Press the \blacktriangle button to call up all following parameters P01 ... P20 in sequence. The parameters already displayed can be accessed by repeatedly pressing the \blacktriangledown button.
- 3 To change the value of a displayed parameter, press the ENTER button for at least one second. The program then changes from parameter selection mode to parameter setting mode.
- 4 Press the \blacktriangle button to increase the parameter value displayed in increments. Press the \blacktriangledown button to decrease the parameter value displayed.
- 5 Press the ENTER button for at least 3 seconds. The new parameter value is stored. The text display will briefly display the message “Store”. The program automatically returns to the parameter selection mode. You can now call up other parameters and check or change their values.
- 6 So that the program changes from parameter selection mode to operation mode, press buttons \blacktriangle and \blacktriangle simultaneously for at least 3 seconds.

If the program is still in parameter setting mode, follow the instructions given under point 5.

i

The symbols shown on the right will be shown in the lower left-hand corner of the text display. They indicate to the operator which mode the equipment is currently in.

+ - Operation mode
 +^ - Parameter selection mode
 +>- Parameter setting mode

If no buttons are pressed for 4 minutes, the RM-216 C automatically returns from parameter selection mode or parameter setting mode to operation mode with the last values stored.

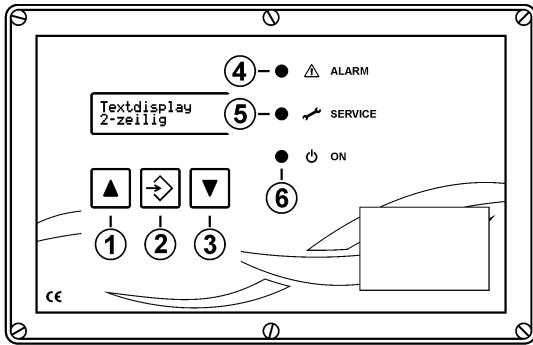

- ① ▲-button for selecting parameters or values (ascending)
- ② ENTER button for entering selected values
- ③ ▼-button for selecting parameters or values (descending)
- ④ LED "ALARM" is on when there is an alarm message (alarm relay pressed)
- ⑤ LED "SERVICE" is on when filter maintenance work is due
- ⑥ LED "ON" is on when the machine is in operation

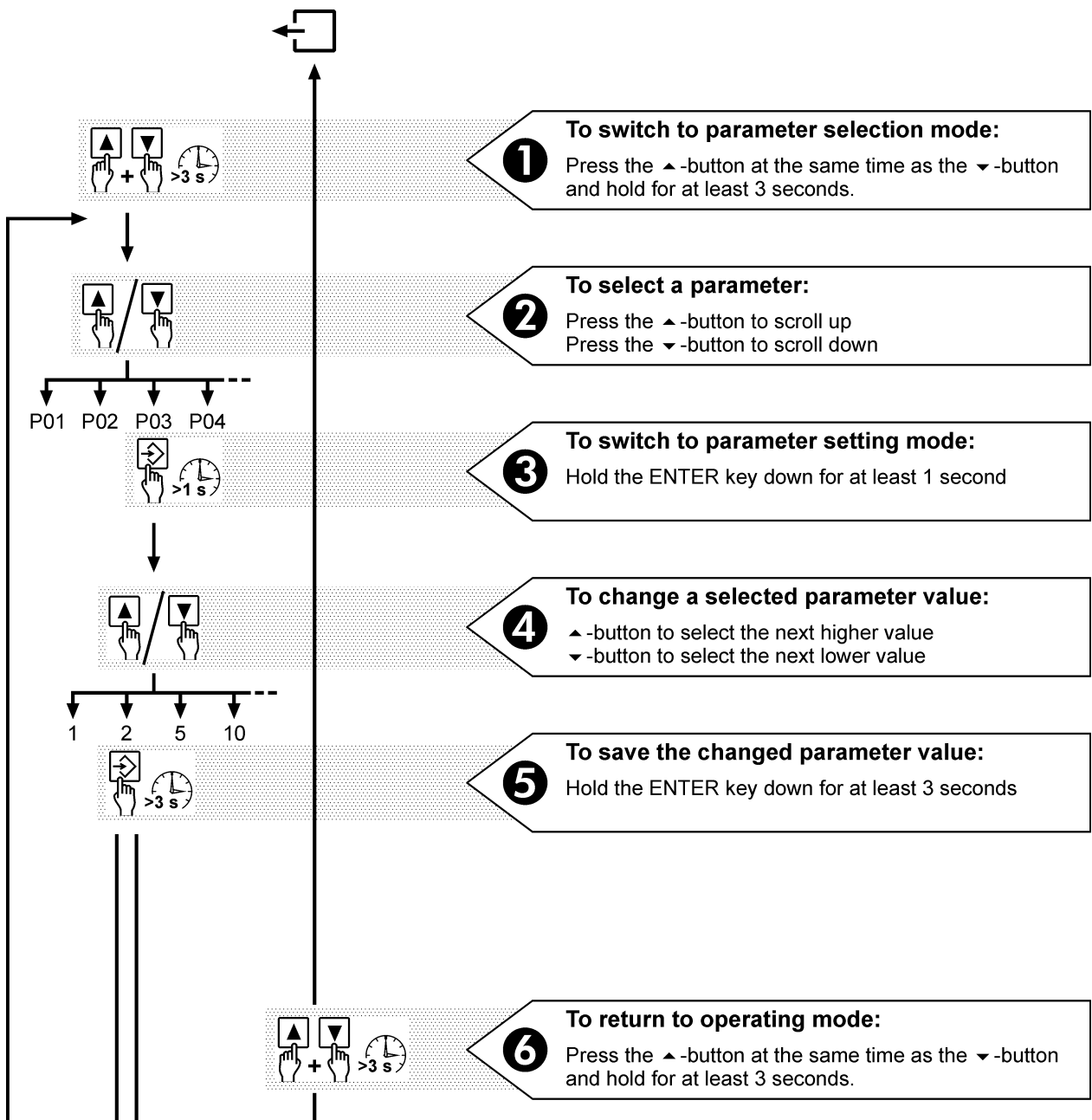

5.3 Parameter list

Parameter no.	Text on the display	Explanation	Factory settings	Setting range
P00	Delta-P Min	Δp -MIN	700 Pa	260 ... 4000 Pa
P01	Delta-P Max	Δp -MAX	1300 Pa	280 ... 4400 Pa
P02	Delta-P Alarm	Δp -Alarm	2300 Pa	300 ... 5000 Pa
P03	Pulse Time	Pulse time	60 ms	30 ... 300 ms
P04	Interval Time	Interval time	10 s	4 ... 500 s
P05	DTC.Interv.Time	Down time interval time	6 s	2 ... 100 s
P06	Total Valve no.	Total no. of valves 1	0	0 ... 128
P07	DTC Down Time Cy	Down time cleaning cycles	6	0 ... 32
P08	Delta-P DTC Max	Parameter to activate down time (DTC modes 2 and 3)	1000 Pa	280 ... 4000 Pa
P09	Delta P DTC Min	Parameter to activate down time (DTC mode 3)	260 Pa	260 ... 2000 Pa
P10	Hours in operati	Operating hours	–	0 ... 250000 h
P11	Text Language	Language for the display text	D	D, GB, F, I, NL, DK, FIN, PL
P12	DP-Display Range	Unit of displayed Δp values	Pa	Pa, mbar, Inch WC, mm WG
P13	DTC Cleaning Mod	Down time cleaning mode (DTC-mode)	2	1 ... 3
P14	Test Mode	0 = Test mode off 1 = Valve test 2 = Input test 3-7 = For manufacturer purposes only	Off (0)	0 ... 7
P15	dP range	Δp range	0 ... 5000 Pa	0 ... 1000 Pa to 0 ... 5000 Pa
P16	Servic.Run Hours	Service operating hours	–	–
P17	Ser.Run Hours AL	Service operating hours alarm	0 h**	0 ... 25000 h**
P18	Ser.Run Hou.Code	Service operating hours code	0	–
P19	DP-Mode	Differential pressure mode	On	On / Off
P20	Setting Lock	Parameter setting lock	On	On / Off

¹ Number of all valves connected to the RM-216 C and to the expansion modules. The parameter is used by the equipment for internal monitoring purposes and need only be set, if expansion modules are fitted. If the equipment detects that the total number of valves set is different from the actual number of valves controlled, an alarm message is issued.

² The Δp measuring range of the 4-20 mA signal output 52, 53 is configurable from 0 ... 1000 Pa to 0 ... 5000 Pa in 500 Pa increments.

³ If the parameter is set to the value 0 h, the alarm is switched off.



The parameters P03, P06, P07, P08, P09, P13 and P18 are protected by a setting lock at the factory. If the values need to be changed, the parameter P20 "Setting lock" Must be set to the value "Off".

The parameters P10, P16 and P17 are only displayed, if the service operating hours code (parameter P18) has been entered.

6 Operating modes

6.1 Test mode

In test mode, the most important functions in the control sequence are checked and shown on the text display. To start test mode, call up parameter no. P14 "Test mode" (see section 5.2 for more information) and select one of the following test modes:

Test mode 1 (Valve test)

Each connected valve is activated in sequence and shown in the text display.

Test mode 2 (Input test)

The signal statuses of the inputs are displayed on the text display.

Test modes 3-7

For manufacturer purposes only.

Test mode 0 (test mode off)

Test mode is switched off.

6.2 Δp -Mode (differential pressure controlled cleaning)

There are two options for switching the differential pressure controlled cleaning on the RM-216 C on and off:

- By setting the parameter P19 "DP-Mode" to the value "On" or "Off"
- By pressing the ENTER button for around 3 seconds



If differential pressure-controlled cleaning is switched off, the text "DP-Mode Off" is shown on the display.

6.3 Down time cleaning modes

Down time cleaning is activated differently depending on the mode selected. Down time cleaning modes 1, 2 and 3 (abbreviated below as DTC modes 1, 2 and 3; Down-Time-Cleaning mode) are available:

DTC mode 1

The down time cleaning is started via the contact connected on input E1 and E2. If the fan is switched off, the contact on E1, E2 must open.

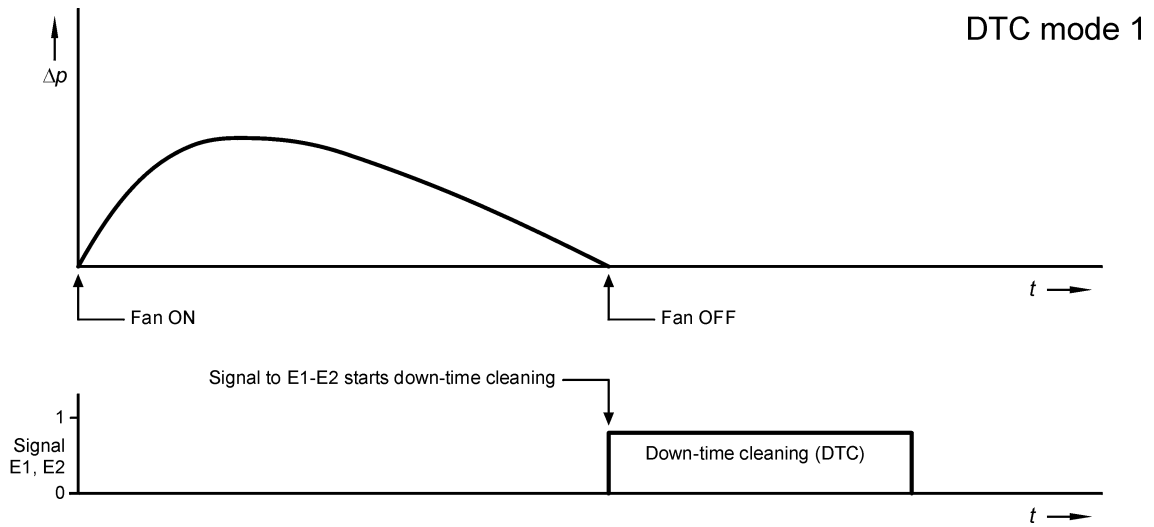

DTC mode 2

The down time cleaning is only started via the contact connected to input E1 and E2 if the differential pressure has exceeded the value $\Delta p_{DTC\ max}$ during operation. If the fan is switched off, the contact on E1, E2 must open.

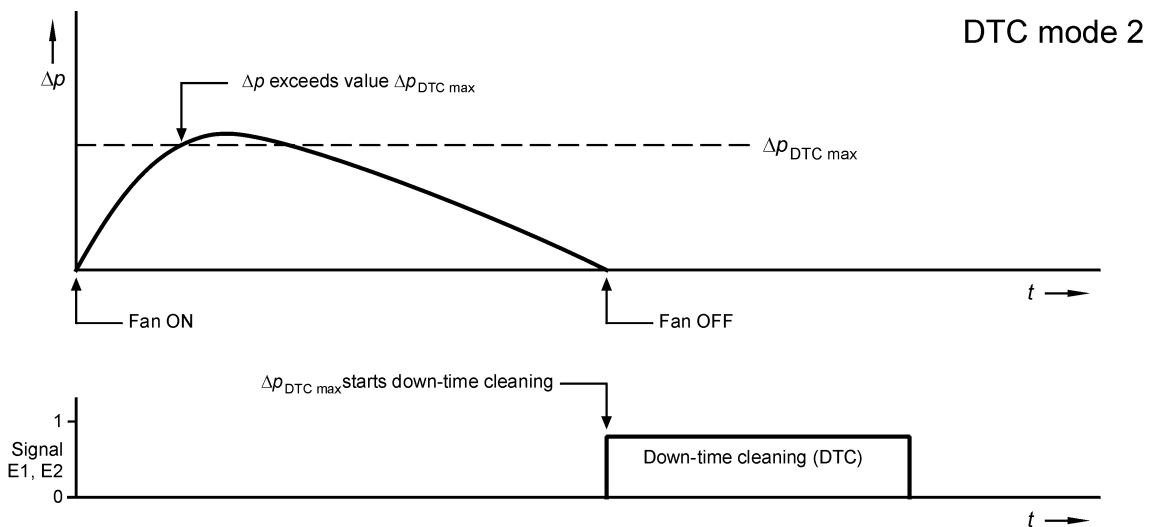

DTC mode 3

The down time cleaning is started when the differential pressure falls below the value Δp DTC min, after the value Δp DTC max has first been exceeded. The signal on input E1, E2 is ignored.

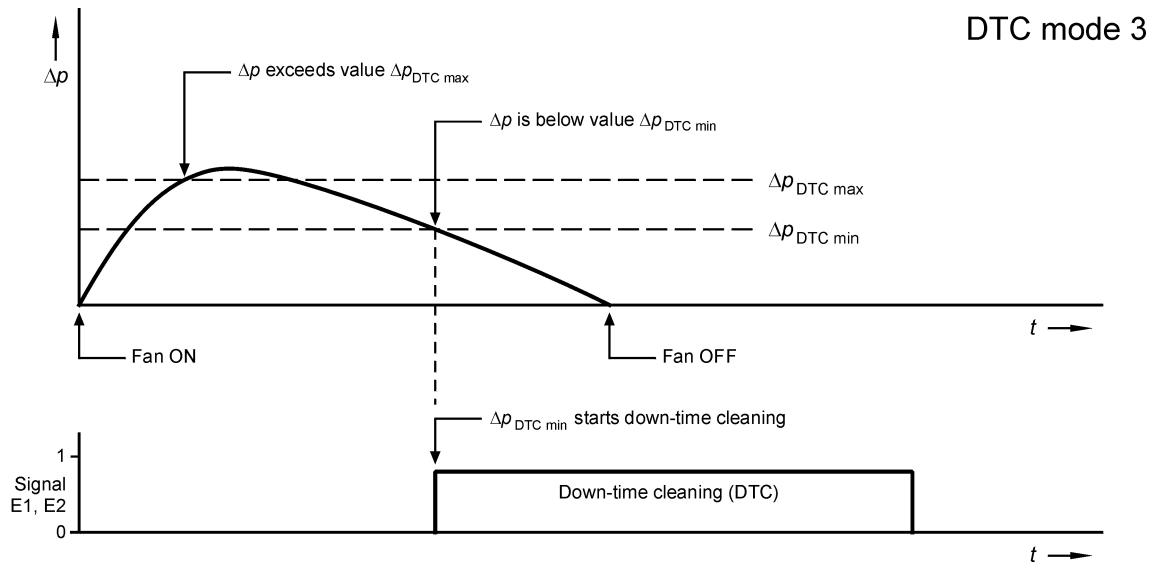

6.4 Cleaning via start/stop input (external Δp switch)

If the cleaning is controlled via an external Δp switch, the isolated contact on the Δp switch must be connected to the start/stop input D1, D2 (terminals 12, 13). The function of the RM-216 C is given in the following table.

If the setting is “ Δp mode OFF”

Contact (input D1, D2)	Cleaning
open	ON
closed	OFF

If the setting is “ Δp mode ON”

Contact (input D1, D2)	Differential pressure Δp	Cleaning
open	$\Delta p > \Delta p\ MAX$	ON
closed	$\Delta p > \Delta p\ MAX$	OFF
open	$\Delta p < \Delta p\ MIN$	OFF
closed	$\Delta p < \Delta p\ MIN$	ON



During down-time cleaning, the start/stop input D1, D2 is inactive.

7 Troubleshooting

Error	Possible causes	Recommended action
The "ON" LED is not lit and input E1, E2 is bridged.	- No mains voltage	- Check power feed
	- Device fuse is defective	- Replace fuse
	- EMERGENCY STOP activated	- Check EMERGENCY STOP
No valve activity	- No control system release	- Bridge input E1, E2
	- Wiring to valves interrupted	- Check cables and electrical connections
	- Magnet coil faulty	- Replace coil
	- Cycle interrupted	- Check hose connections. Set different values for Δp control
No down time cleaning	- Parameter P07 = 0 (down time cleaning cycles)	- Set parameter P07 "Down time cleaning cycles" to a different value
	- There is no signal from the valve controller (DTC modes 1-2)	- Activate signal to input I1, I2
Cleaning ineffective	- Interval time too long	- Set parameter P04 "Interval time" to a lower value
	- Pressure too low	- Set pressure to 6 ... 8 bar (min. 5 bar) - Set parameter P04 "Interval time" to a higher value
	- Valve faulty	- Check / replace valves
	- Pulse time too short	- Set parameter P03 "Pulse time" to a higher value
	- Cycle often interrupted	- Check differential pressure monitor and hose connections
Differential pressure display error	- Hose connection error	- Drain hoses. Clean joints between hose connections and the filter casing with compressed air (only towards the filter, never towards the sensor) - Fit the hoses so there are no kinks - Check the hose connections for water, kinks, etc.
"Alarm" LED on	- The number of valves is set incorrectly	- Set parameter P06 "Total no. of valves" correctly
	- Δp -Alarm	- Observe the service instructions for the filter

7.1 Instructions for the replacement of the device fuse

- Switch off the supply voltage of the device at the in-line fuse element or main switch and take precautions against reactivation.
- Check whether main supply line carries no voltage.
- Unscrew the six screws of the RM-216 C housing cover and remove the cover.
- Pull off the transparent plastic cap of the fuse holder (see picture).

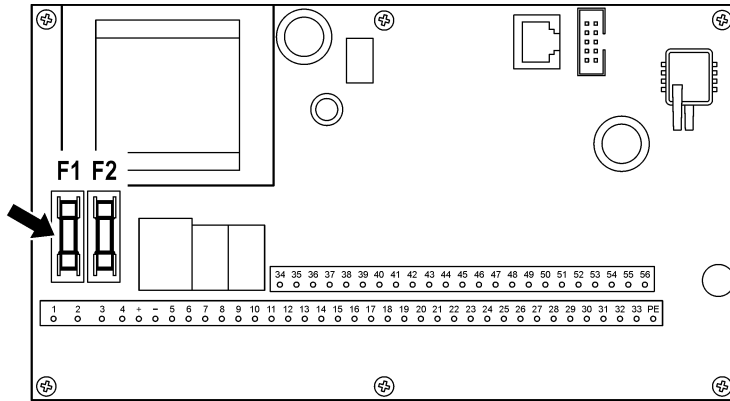

- Pull the fuse from the holder.
- Insert the new fuse into the holder.



Use only the UL listed fuses that are mentioned in chapter 11 “Technical specifications“ on page 21.

(Shut-off after one hour at 135% of the nominal current.)

- Place the transparent plastic cap of the fuse holder.
- Position the housing cover on the bottom part of the housing and tighten the six screws evenly.
- Switch on the supply voltage again.

7.2 Cleaning the controller

Wipe only with a damp cloth if outside of device is soiled.

7.3 Manufacturing

The filter control system RM-216 C was manufactured by:

RECO Gesellschaft für Industriefilterregelung mbH
Junkersring 11
D-53844 Troisdorf
Germany
Tel.: +49 (0) 2241 39704-0

for:

Norbert Heinrich
Automatisierungstechnik
Feldstraße 16
32549 Bad Oeynhausen
Germany
Fon +49 (0) 5734 6002318
Fax +49 (0) 5734 6002319
E-mail: mail@nheinrich.de



Please contact Norbert Heinrich to obtain technical support.

8 Text messages on the display

Display	Explanation
<div style="border: 1px solid black; padding: 2px;"> Reset RM200VXX + - XXXX Pa </div>	Reset status, text version and differential pressure. The text message is displayed for approx. 1 second after the voltage is switched on.
<div style="border: 1px solid black; padding: 2px;"> Stand By + - XXXX Pa </div>	Controller is not enabled through inputs I1 and I2.
<div style="border: 1px solid black; padding: 2px;"> Cleaning Off + - XXXX Pa </div>	Controller is enabled through inputs I1 and I2. The Max Δp switching point has not yet been reached.
<div style="border: 1px solid black; padding: 2px;"> Cleaning On + - XXXX Pa </div>	Controller is enabled through inputs I1 and I2 and the Max Δp switching point has been exceeded.
<div style="border: 1px solid black; padding: 2px;"> Cleaning On + - XXXX Pa </div> <p>alternating with</p> <div style="border: 1px solid black; padding: 2px;"> DP-Max Alarm + - XXXX Pa </div>	Controller is enabled through inputs I1 and I2 and the Δp alarm switching point has been exceeded.
<div style="border: 1px solid black; padding: 2px;"> Extern Clean ON + - XXXX Pa </div>	Controller is enabled through inputs I1 and I2 and the Max Δp switching point has not yet been reached with inputs D1 and D2 bridged.
<div style="border: 1px solid black; padding: 2px;"> Extern Clean OFF + - XXXX Pa </div>	Controller is enabled through inputs I1 and I2 and the Max Δp switching point has been exceeded with inputs D1 and D2 bridged.
<div style="border: 1px solid black; padding: 2px;"> DP-Mode Off + - XXXX Pa </div>	Δp mode switched off
<div style="border: 1px solid black; padding: 2px;"> DTC Cleaning ON + - 000 Pcs </div>	Down time cleaning active
<div style="border: 1px solid black; padding: 2px;"> Call Service + - XXXX Pa </div>	The alarm switching point for the service hours counter has been exceeded.
<div style="border: 1px solid black; padding: 2px;"> RM-LVX Alarm + - XXXX Pa </div>	A connected I/O module RM-LV8 or RM-LV16 is out of order or the total number of valves (parameter P06) is set incorrectly.
<div style="border: 1px solid black; padding: 2px;"> Lock </div>	Locked parameter in parameter selection mode

XXXX The differential pressure value displayed depends on the parameter setting.

9 Details on the equipment function

Differential pressure controlled cleaning

The cleaning is controlled by means of two Δp switch points which can be set independently of one another. It starts when the value Δp -MAX is reached. All connected solenoid valves are controlled using the preset values for the pulse time and the interval time, starting with the interval time. If the differential pressure reaches the value Δp -MIN, cleaning stops. To monitor the filter, a Δp alarm switch point (Δp alarm) can be set.

Cleaning starts at the first valve. If cleaning is interrupted using the Δp controller or the start/stop input D1, D2, the controller sequence is continued with the next cleaning process. The cleaning then starts at the valve following the last valve activated.

If the control is reactivated following a mains voltage failure, a restart is carried out.

Input E1, E2 “Down time cleaning” (terminals 10, 11)

If the control is working in DTC mode 1 or DTC mode 2 (Down-Time-Cleaning mode. See also section 6.3), the control must be switched on and off via input E1, E2. The input should be operated in isolation. Ideally, the auxiliary contact of the fan contactor should be connected here.

- Closing the contact on input E1, E2 switches on the control unit.
- In DTC mode 1, opening the contact on input E1, E2 executes the down time cleaning cycles and then switches the device off. In DTC mode 2, the same function is only carried out if differential pressure exceeded the value Δp DTC max during the last operating period.
- In DTC mode 3, the down-time cleaning cycles are activated if differential pressure exceeded the value Δp DTC max during the last operating period and then fell below the value Δp DTC min.

Relay output S1, S2 to control extractor elements (terminals 8, 9)

If automatic components for dust removal (extractor elements) are fitted, these need to be in operation during cleaning and during down time cleaning. Connect the cut-out for controlling these drive units to the isolated output S1, S2.

“Alarm” relay output A1, A2, A3 (terminals 5, 6, 7)

As soon as the supply voltage is present on the RM-216 C, relay contact A1, A2 closes (terminals 5, 6) and contact A2, A3 opens (terminals 6, 7). In the following situations, relay contact A1, A2 opens and contact A2, A3 closes:

- Supply voltage failure
- Failure of a voltage internal to the equipment
- Fault in a connected I/O module
- Total number of valves is set incorrectly (parameter P06)
- The Δp alarm switching point has been exceeded.

10 Glossary

Term	Explanation
Bulkhead connector	Connections for fitting the differential pressure measurement hoses.
Cleaning	Cleaning the filter elements using compressed air pulses.
Compressed air pulse cleaning	Cleaning of the filter elements using compressed air pulses.
Differential pressure	Difference between the air pressures Δp on the pure gas side (behind the filter element) and the crude gas side (in front of the filter element) of the filter.
Down time cleaning	Cleaning the filter elements after the system is shut down for a set duration or number of cycles.
Down time cleaning cycles	The number of cleaning cycles performed in the down time cleaning.
Down time cleaning input	Input on the RM-216 C for starting the down time cleaning.
Down time interval time	Pause time during the down time cleaning.
DTC mode	<u>D</u> own <u>T</u> ime <u>C</u> leaning mode The way in which the down time cleaning is started.
Expansion module	If the filter has more than 16 valves, expansion modules of type RM-LV8 (for 8 valves) or RM-LV16 (for 16 valves) are required. A maximum of 7 type RM-LV16 expansion modules can be connected to the main RM-216 C equipment. With the outputs on the main equipment, this makes a maximum of 128 valve outputs available.
Extractor element	Device for extracting the filter casing from the dust deposited. E.g. cellular wheel sluice, through conveyor worm.
Extractor element contactor	Contactors which switch an extractor element drive unit on and off.
I/O module	Input/output module (module for the input and output of control signals)
Operation mode	Status of the RM-216 C in which the equipment is ready for operation.
Parameter selection mode	Status of the RM-216 C in which the equipment operator can select a parameter.
Parameter setting lock	The parameters P03, P06, P07, P08, P09, P13 and P18 are protected by a setting lock at the factory. If the values need to be changed, the parameter P20 "Setting lock" Must be set to the value "Off".
Parameter setting mode	Status of the RM-216 C in which the equipment operator can set a parameter.
Pause time (also Interval time)	Time period between two consecutive control pulses from the valve outputs when the cleaning is running.
Pulse time	Duration of a control pulse on the valve outputs.
Service operating hours alarm	Alarm issued when the operating hours set for the maintenance interval has elapsed.
Service operating hours code	Code which needs to be entered to change the set value for the service operating hours.
Setting lock	See Parameter setting lock

Term	Explanation
Solenoid valve	(also relay valve) electromagnetically operated valve for the pneumatic triggering of the filter membrane valves. The membrane valves in turn release the compressed air strokes for filter cleaning.
Start/stop input	Input on the RM-216 C for starting and stopping the cleaning via an external Δp switch.
Total no. of valves	Number of all valves connected to the RM-216 C and to the expansion modules.
Δp alarm	Differential pressure value at which an alarm is issued.
Δp -MAX	Differential pressure value at which the cleaning is started.
Δp -MIN	Differential pressure value at which the cleaning is stopped.
Δp mode	Operating mode of the filter control in which the cleaning of the filter elements depends on the differential pressure Δp .
Δp remote display	Display showing the differential pressure of the filter in a control room.
Δp switch	Switch which is triggered by a differential pressure value set and which activates the filter cleaning.

11 Technical specifications

Application	Data																
Supply voltages	230 V AC $\pm 10\%$ 50-60 Hz 110 V ... 120 V AC $\pm 10\%$ 50-60 Hz Power consumption: max. 53 VA Back-up fuse: max. 4 A 26 V ... 28 V DC Power consumption: max. 30 W Back-up fuse: max. 4 A  A UL class 2 power supply unit is recommended for the operation of the filter controller with extra low voltage.																
Signal inputs	24 V DC, operate ensuring isolation																
Signal output	Relay outputs, max. 2 A, 250 V or 1 A, 30 V DC																
Control outputs for valves	For valves with a rated voltage of 24 V DC, can be expanded to 128 outputs, Output power in pulse mode 42 Watt																
Outputs for expansion modules	Supply voltage and pulse wires to the expansion modules																
Signal output F1, F2	4-20 mA \cong 0 ... x Pa*; resistance 500 Ω																
Δp measuring range	configurable from 0 ... 1000 Pa to 0 ... 5000 Pa in 500 Pa increments																
Measurement sensor	piezoresistant, excessive pressure-safe up to 120 kPa																
Fuses	F1 (230 V): M 0.2 A 250 V / 5 x 20 mm Type Bell 5MT 200 mA (ESKA UL 521.010) F2 (110 V): M 0.3 A 250 V / 5 x 20 mm Type Bell 5MT 300 mA (ESKA UL 521.012) Extra low voltage: Fusing via PTC resistor																
Electrical connections	Screw terminals Permissible wire gauge single-wire: 22 ... 16 AWG / 0.5 ... 1.5 mm ² Flexible: 22 ... 16 AWG / 0.5 ... 1.5 mm ²																
Cable glands	<table border="1"> <thead> <tr> <th>Size</th> <th>Sealing range</th> <th>Cord diameter range</th> <th>Installation torque</th> </tr> </thead> <tbody> <tr> <td>M16x1.5</td> <td>5 ... 10 mm</td> <td>5.6 ... 10 mm</td> <td>2.0 Nm</td> </tr> <tr> <td>M20x1.5</td> <td>8 ... 13 mm</td> <td>9 ... 13 mm</td> <td>2.7 Nm</td> </tr> <tr> <td>M25x1.5</td> <td>11 ... 17 mm</td> <td>13 ... 17 mm</td> <td>5.0 Nm</td> </tr> </tbody> </table>	Size	Sealing range	Cord diameter range	Installation torque	M16x1.5	5 ... 10 mm	5.6 ... 10 mm	2.0 Nm	M20x1.5	8 ... 13 mm	9 ... 13 mm	2.7 Nm	M25x1.5	11 ... 17 mm	13 ... 17 mm	5.0 Nm
Size	Sealing range	Cord diameter range	Installation torque														
M16x1.5	5 ... 10 mm	5.6 ... 10 mm	2.0 Nm														
M20x1.5	8 ... 13 mm	9 ... 13 mm	2.7 Nm														
M25x1.5	11 ... 17 mm	13 ... 17 mm	5.0 Nm														
Temperature range	-20°C to +50°C																
Degree of protection	Housing IP-66 not evaluated by UL / Type 5 Installation torque of cover screws: 1,5 Nm																
Dimensions	See chapter 3 "Assembly"																
Weight	approx. 0.8 kg																
Installation height	max. 2000 m above M.S.L.																

* configurated Δp measuring range

Disclaimer

The contents of this documentation has been verified for correctness and completeness. Nevertheless, errors can not be excluded so that we cannot guarantee the correctness of this information. Subject to alterations at any time.