

SB Series Bladder Accumulators



Description

Bladder accumulators are a very versatile and cost effective option for numerous types of hydraulic systems involving energy storage, shock absorption, pulsation dampening, leakage loss compensation and volume compensation. They are a first choice for a great variety of general applications and have the widest range of standard sizes and model options. Bladder accumulators also have very quick shock response characteristics in sizes much larger than diaphragm accumulators (see pg. 31)

Construction

HYDAC bladder accumulators consist of a welded or forged pressure vessel (*shell*), a bladder and ports for gas and fluid inlet. The gas and fluid sides are separated by the bladder.

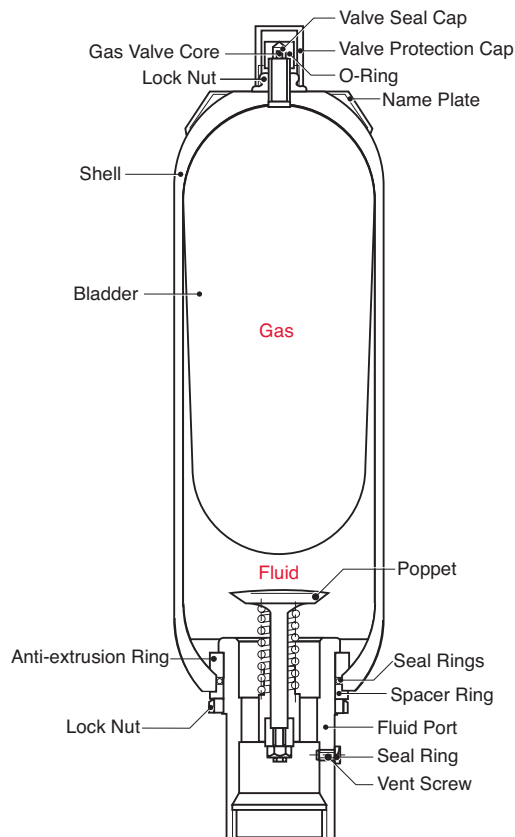

Bladder Materials

Not all fluids are compatible with every elastomer at all temperatures. Therefore, HYDAC offers the following choice of elastomers:

- NBR (*Standard Nitrile*)
- LT-NBR (*Low Temperature Nitrile*)
- ECO (*Epichlorohydrin*)
- IIR (*Butyl*)
- FPM (*Fluoroelastomer*)
- Others (*available upon request*)

To determine which material is appropriate...

ALWAYS REFER TO FLUID MANUFACTURER'S RECOMMENDATION

Corrosion Protection

For use with certain aggressive or corrosive fluids, or in a corrosive environment, HYDAC offers protective coatings and corrosive resistant materials (i.e. stainless steel) for the accumulator parts that come in contact with the fluid, or are exposed to the hostile environment.

Mounting Position

HYDAC bladder accumulators can be installed in any orientation depending upon the application. When installing vertically or at an angle, the fluid port must be at the bottom. On certain applications listed below, specific positions are preferable:

- Energy Storage:
vertical
- Pulsation Dampening:
any position from vertical to horizontal
- Maintaining Constant Pressure:
any position from vertical to horizontal
- Volume Compensation:
any position from vertical to horizontal

Caution: Mounting a HYDAC bladder accumulator horizontally or at an angle will decrease the amount of usable volume available.

System Mounting

HYDAC bladder accumulators are designed to be screwed directly onto the system. We also recommend the use of our mounting components, which are detailed on page 85, to minimize risk of failure due to system vibrations.

Applications

Some common applications of bladder accumulators are:

- Agricultural Machinery & Equipment
- Forestry Equipment
- Oil Field & Offshore
- Machine Tools
- Mining Machinery & Equipment
- Mobile & Construction Equipment
- Off-Road Equipment

For specific examples of applications using bladder accumulators, please see page 89-90.

Model Code

Model Codes containing RED selections are non-standard items – Contact HYDAC for information and availability
Not all combinations are available

SB 330 - 20 A 1 / 112 S - 210 C XXX

Series

- SB 330 = Bladder accumulator (3000 psi, Typically)
- SB 600 = Bladder accumulator (5000 psi, Typically)

Design

- (omit) = Standard (bottom repairable)
- N = Modified Flow (396 gpm)
- H = High Flow (480 gpm)
- TR = Standard (top repairable)
- NTR = Modified Flow (396 gpm) (top repairable)

Size (in Liters, see dimension tables on following pages for most common sizes)

- 1 = 1 quart
- 4 = 1 gallon
- 6 = 1.5 gallons
- 10 = 2.5 gallons
- 20 = 5 gallons
- 32 = 10 gallons
- 42 = 11 gallons
- 54 = 15 gallons

Line Connection

- A = Threaded
- F = Flanged

Gas Port

- 1 = Standard model, HYDAC gas valve version 4 (8V1 - ISO 4570)

Material Code

Depending on Application

- 112 = Standard for oil service (mineral oil)

Fluid Port

- 0 = Synthetic coated carbon steel (PTFE solid film, internal & external for water service)
- 1 = Carbon steel
- 2 = High strength stainless steel (typically 17-4 PH)
- 3 = Stainless steel (corrosion resistance, typically 316 ss)
- 4 = Chemically plated carbon steel (internal & external for water service)
- 6 = Low temperature carbon steel (<-40°F, min)

Shell

- 0 = Synthetic coated carbon steel (PTFE solid film, internal & external for water service)
- 1 = Carbon steel
- 2 = Chemically plated carbon steel (internal & external for water service)
- 6 = Low temperature carbon steel (<-40°F, min)
- 7 = Others available on request

Bladder Compound

- 2 = NBR (Buna N)
- 3 = ECO (Hydrin)
- 4 = IIR (Butyl)
- 5 = LT-NBR (low temp. Buna)
- 6 = FPM (Fluoroelastomer)
- 7 = Others (available on request)

Compound	Oper. Temp Range	Typical Fluids
NBR	5° to 180°F	mineral oils
	32° to 180°F	water & water-glycols (5% minimum glycol)
LT-NBR	-50° to 180°F	mineral oils
ECO...113...	-20° to 250°F	mineral oils
ECO...663...	-40° to 250°F	mineral oils (with low temperature CS shell)
IIR	-20° to 200°F	phosphate esters & brake fluids
FPM	5° to 300°F	chlorinated hydrocarbons

Country of Installation

- S = USA
- S1 = Canada (CRN registered)
- W1 = ABS Type Approval
- W3 = DNV Type Approval
- U = PED/CE

(for other countries see page 2 for proper code designation)

Maximum Working Pressure in bar

- 210 = 3000 psi
- 345 = 5000 psi

Fluid Port Connection

- Threaded
 - A = BSPP (ISO 228)
 - B = Metric (DIN 13)
 - C = SAE (ANSI B1.1)
 - D = NPT (ANSI B1.2)
- Flanged
 - E = SAE 2" - 3000 psi (Code 61)
 - F = SAE 1 1/2" - 6000 psi (Code 62)
 - G = SAE 1 1/4" - 3000 psi (Code 61) (only available in sizes 4 liters & 6 liters)
 - H = SAE 1" - 6000 psi (Code 62) (only available in sizes 1 liter & 4 liters)

Gas Precharge Pressure (P_o) in bar

- xxx = 3 digits

Dimensions Bottom Repairable

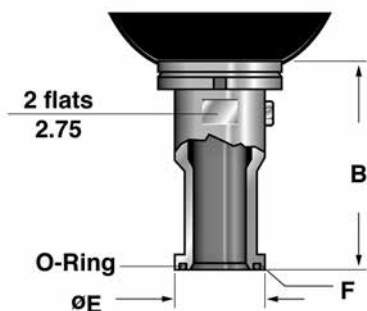
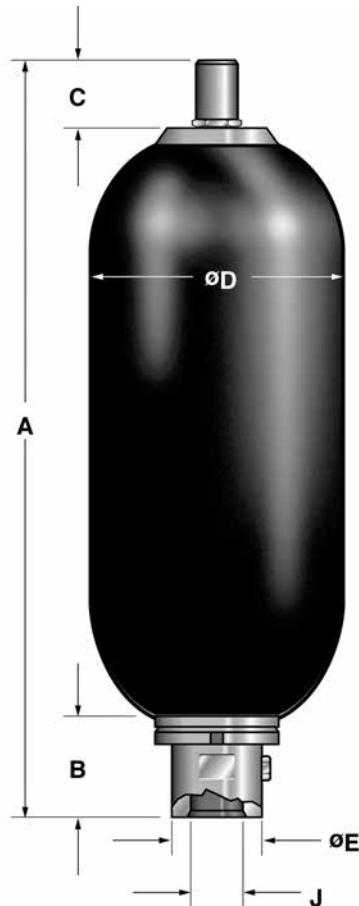

SB 330... (3000 psi)

Size (L)	Nom. Vol. (gal.)	Eff. Gas Vol. in ³ / (gal.)	Weight	A	B ⁽¹⁾	C	ØD	ØE	Thread-J		Q ⁽²⁾ gpm
									SAE	NPTF BSPP	
1	1/4	66 (0.29)	10 (4.5)	12.0 (303)	2.0 (51)	2.3 (58)	4.6 (117)	1.4 (36)	1 1/16-12 UN (SAE-12)	3/4"	60
4	1	226 (0.98)	30 (14)	16.3 (415)	2.6 (66)	2.3 (58)	6.6 (168)	2.1 (53)	1 5/8-12 UN (SAE-20)	1 1/4"	160
6	1 1/2	340 (1.47)	33 (15)	20.5 (521)	2.6 (66)	2.3 (58)	6.6 (168)	2.1 (53)	1 5/8-12 UN (SAE-20)	1 1/4"	160
10	2 1/2	566 (2.45)	86 (39)	22.0 (559)	3.1 (80)	2.3 (58)	9.1 (231)	3.0 (76)	1 7/8-12 UN (SAE-24)	2"	240
20	5	1125 (4.87)	140 (63)	34.5 (876)	3.1 (80)	2.3 (58)	9.1 (231)	3.0 (76)	1 7/8-12 UN (SAE-24)	2"	240
32	10	2080 (9.00)	226 (102)	54.7 (1390)	3.1 (80)	2.3 (58)	9.1 (231)	3.0 (76)	1 7/8-12 UN (SAE-24)	2"	240
42	11	2320 (10.04)	270 (123)	60.2 (1530)	3.1 (80)	2.3 (58)	9.1 (231)	3.0 (76)	1 7/8-12 UN (SAE-24)	2"	240
54	15	3205 (13.87)	330 (150)	78.3 (1990)	3.1 (80)	2.3 (58)	9.1 (231)	3.0 (76)	1 7/8-12 UN (SAE-24)	2"	240

See notes at bottom of page

Dimensions are for general information only, all critical dimensions should be verified.
Dimensions are in inches/(mm) and lbs/(kg)

SB 600... (5000 psi)

Size (L)	Nom. Vol. (gal.)	Eff. Gas Vol. in ³ / (gal.)	Weight	A	B ⁽¹⁾	C	ØD	ØE	Thread-J		Q ⁽²⁾ gpm
									SAE	NPTF BSPP	
1	1/4	66 (0.29)	17 (7.7)	13.2 (335)	2.4 (62)	2.3 (58)	4.8 (122)	2.1 (53)	1 5/8-12 UN (SAE - 20)	1 1/4"	160
4	1	226 (0.98)	33 (15)	16.3 (415)	2.5 (64)	2.3 (58)	6.8 (173)	2.1 (53)	1 5/8-12 UN (SAE - 20)	1 1/4"	160
10	2 1/2	566 (2.45)	114 (52)	22.4 (568)	3.1 (80)	2.8 (70)	9.1-9.7 (232-247)	3.0 (76)	1 7/8-12 UN (SAE - 24)	2"	240
20	5	1125 (4.87)	162 (73)	35.0 (888)	3.1 (80)	2.8 (70)	9.1-9.7 (232-247)	3.0 (76)	1 7/8-12 UN (SAE - 24)	2"	240
32	10	2080 (9.00)	250 (113)	55.2 (1402)	3.1 (80)	2.8 (70)	9.1-9.7 (232-247)	3.0 (76)	1 7/8-12 UN (SAE - 24)	2"	240
54	15	3180 (13.77)	370 (168)	78.8 (2002)	3.1 (80)	2.8 (70)	9.1-9.7 (232-247)	3.0 (76)	1 7/8-12 UN (SAE - 24)	2"	240

See notes at bottom of page

Dimensions are for general information only, all critical dimensions should be verified.
Dimensions are in inches/(mm) and lbs/(kg)

Split Flange Connection (sizes 10 - 54)

Series	B	ØE	F Split Flange Connection	Q ⁽²⁾ gpm
SB 330 SB 330 TR ⁽³⁾	4.1 (104)	2.8 (71.4)	SAE 2" - 3000 psi Code 61	240
SB 600 SB 600 TR ⁽³⁾	5.5 (140)	2.5 (63.5)	SAE 1 1/2" - 5000 psi Code 62	240

NOTE: Higher pressure may be available. Please consult HYDAC for more information.

1) Applies to SAE thread type only. For Split Flange, see separate chart and illustration.

2) Maximum discharge flow rate recommended for vertically mounted accumulators.

3) Sizes 10 to 54 only.

Top Repairable and Modified Flow

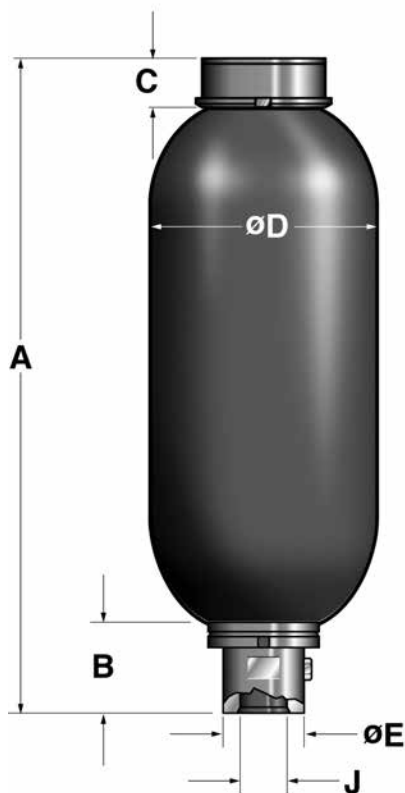

SB 330 TR... (3000 psi)

Size (L)	Nom. Vol. (gal.)	Eff. Gas Vol. in ³ / (gal.)	Weight	A	B ⁽¹⁾	C	ØD	ØE	Thread-J		Q ⁽²⁾ gpm
									SAE	NPTF BSPP	
10	2.5	566 (2.45)	94 (43)	21.3 (540)	3.1 (80)	1.6 (40)	9.1 (231)	3.0 (76)	1 7/8-12 UN (SAE - 24)	2"	240
20	5	1125 (4.87)	140 (63)	34.8 (883)	3.1 (80)	1.6 (40)	9.1 (231)	3.0 (76)	1 7/8-12 UN (SAE - 24)	2"	240
32	10	2080 (9.00)	226 (102)	55.0 (1397)	3.1 (80)	1.6 (40)	9.1 (231)	3.0 (76)	1 7/8-12 UN (SAE - 24)	2"	240
42	11	2320 (10.04)	270 (123)	60.2 (1530)	3.1 (80)	1.6 (40)	9.1 (231)	3.0 (76)	1 7/8-12 UN (SAE - 24)	2"	240
54	15	3205 (13.87)	330 (150)	78.6 (1997)	3.1 (80)	1.6 (40)	9.1 (231)	3.0 (76)	1 7/8-12 UN (SAE - 24)	2"	240

See notes at bottom of page

Dimensions are for general information only, all critical dimensions should be verified.

Dimensions are in inches/(mm) and lbs/(kg)

SB 600 TR... (5000 psi)

Size (L)	Nom. Vol. (gal.)	Eff. Gas Vol. in ³ / (gal.)	Weight	A	B ⁽¹⁾	C	ØD	ØE	Thread J		Q ⁽²⁾ gpm
									SAE	NPTF BSPP	
10	2.5	566 (2.45)	126 (57)	20.9 (531)	3.1 (80)	1.6 (40)	9.1-9.7 (232-247)	3.0 (76)	1 7/8-12 UN (SAE-24)	2"	240
20	5	1125 (4.87)	172 (78)	33.5 (851)	3.1 (80)	1.6 (40)	9.1-9.7 (232-247)	3.0 (76)	1 7/8-12 UN (SAE-24)	2"	240
32	10	2080 (9.00)	260 (118)	53.7 (1364)	3.1 (80)	1.6 (40)	9.1-9.7 (232-247)	3.0 (76)	1 7/8-12 UN (SAE-24)	2"	240
54	15	3205 (13.87)	380 (172)	77.3 (1964)	3.1 (80)	1.6 (40)	9.1-9.7 (232-247)	3.0 (76)	1 7/8-12 UN (SAE-24)	2"	240

See notes at bottom of page

Dimensions are for general information only, all critical dimensions should be verified.

Dimensions are in inches/(mm) and lbs/(kg)

SB 330 NTR... (3000 psi, Modified Flow)

Size (L)	Nom. Vol. (gal.)	Eff. Gas Vol. in ³ / (gal.)	Weight	A	B ⁽¹⁾	C	ØD	ØE	Thread J		Q ⁽²⁾ gpm
									SAE	NPTF BSPP	
10	2.5	566 (2.45)	94 (43)	21.3 (540)	3.1 (80)	1.6 (40)	9.1 (231)	3.0 (76)	1 7/8-12 UN (SAE-24)	2"	240
20	5	1125 (4.87)	140 (63)	34.8 (883)	3.1 (80)	1.6 (40)	9.1 (231)	3.0 (76)	1 7/8-12 UN (SAE-24)	2"	240
32	10	2080 (9.00)	226 (102)	55.0 (1397)	3.1 (80)	1.6 (40)	9.1 (231)	3.0 (76)	1 7/8-12 UN (SAE-24)	2"	240
54	15	3205 (13.87)	330 (150)	77.3 (1964)	3.1 (80)	1.6 (40)	9.1 (231)	3.0 (76)	1 7/8-12 UN (SAE-24)	2"	240

Dimensions are for general information only, all critical dimensions should be verified.

Dimensions are in inches/(mm) and lbs/(kg)

Note:

- 1) Applies to SAE thread type only. For Split Flange, see chart and illustration on previous page.
- 2) Maximum discharge flow rate recommended for vertically mounted accumulators.

Water Service

*RED selections are non-standard items – Contact HYDAC for information and availability
Not all combinations are available*

Size (L)	Effective Gas Vol (in3)	MAWP psi/(bar)	Model Code	P/N	Fluid Connection Thread Size
1	66	3000 (210)	SB330-1A1/002S-210C	2055285	SAE 1 1/16" - 12 UN
4	226	3000 (210)	SB330-4A1/002S-210C	2055070	SAE 1 5/8" - 12 UN
4	226	3000 (210)	SB330-4A1/005S-210C	2092089	SAE 1 5/8" - 12 UN
4	226	3000 (210)	SB330-4A1/006S-210D (USES 1.25" NPT ADAP)	2091080	1 1/4" NPT
6	340	3000 (210)	SB330-6A1/002S-210D (USES 1.25" NPT ADAP)	2092310	1 1/4" NPT
10	566	3000 (210)	SB330-10A1/002S-210C	2055224	SAE 1 7/8" - 12 UN
10	566	3000 (210)	SB330-10A1/002S-210D	2087571	2" NPT
10	566	3000 (210)	SB330-10F1/002S-210E	2069474	Flanged SAE 2" (Code 61)
20	1125	3000 (210)	SB330-20A1/002S-210C	2054720	SAE 1 7/8" - 12 UN
20	1125	3000 (210)	SB330-20A1/002S-210D	2087570	2" NPT
20	1125	3000 (210)	SB330-20A1/002S1-210A CRN	2082666	2" BSPP
20	1125	3000 (210)	SB330-20A1/002S1-210C CRN	2084359	SAE 1 7/8" - 12 UN
20	1125	3000 (210)	SB330-20F1/002S-210E	2072909	Flanged SAE 2" (Code 61)
32	2080	3000 (210)	SB330-32A1/002S-210C	2083387	SAE 1 7/8" - 12 UN
32	2080	3000 (210)	SB330-32A1/002S-210D	2063921	2" NPT
32	2080	3000 (210)	SB330-32F1/002S-210E	2072536	Flanged SAE 2" (Code 61)
54	3205	3000 (210)	SB330-54A1/002S-210C	2055269	SAE 1 7/8" - 12 UN
54	3205	3000 (210)	SB330-54A1/002S-210D	2069311	2" NPT
54	3205	3000 (210)	SB330-54A1/002S1-210A CRN	2082667	2" BSPP
54	3205	3000 (210)	SB330-54F1/002S-210E	2055105	Flanged SAE 2" (Code 61)

1	66	5000 (345)	SB600-1A1/002S-345C	2054911	SAE 1 5/8" - 12 UN
1	66	5000 (345)	SB600-1F1/002S-345H	2094814	Flanged SAE 1" (Code 62)
4	226	5000 (345)	SB600-4A1/002S-345C	2055063	SAE 1 5/8" - 12 UN
10	566	5000 (345)	SB600-10A1/002S-345C	2055093	SAE 1 7/8" - 12 UN
10	566	5000 (345)	SB600-10A1/002S1-345C CRN	2093123	SAE 1 7/8" - 12 UN
10	566	5000 (345)	SB600-10F1/002S-345F	2089028	Flanged SAE 1 1/2" (Code 62)
20	1125	5000 (345)	SB600-20A1/002S-345C	2056383	SAE 1 7/8" - 12 UN
20	1125	5000 (345)	SB600-20F1/002S-345F	2083359	Flanged SAE 1 1/2" (Code 62)
32	2080	6000 (414)	SB600-32A1/002S-414A	2070756	2" BSPP
32	2080	5000 (345)	SB600-32F1/002S-345F	2076097	Flanged SAE 1 1/2" (Code 62)
54	3180	5000 (345)	SB600-54A1/002S-345C	2062971	SAE 1 7/8" - 12 UN
54	3180	5000 (345)	SB600-54A1/006S-345C	2094879	SAE 1 7/8" - 12 UN
54	3180	5000 (345)	SB600-54F1/002S-345F	2074828	Flanged SAE 1 1/2" (Code 62)

Model Code

Model Codes containing RED selections are non-standard items – Contact HYDAC for information and availability
Not all combinations are available

SB 90 - 20 S 11/ 332S1-82C

Series
SB 90 = Bladder accumulator (1190 psi, Nominal)

Size
10 = 2.5 gal
20 = 5 gal
35 = 10 gal
50 = 15 gal

Line Connection
S = Threaded (SAE Lock Nut)
F = Flanged (SAE Lock Nut)

Gas Port
11 = 2pc gas valve (MS28889-2)

Fluid port
3 = 316 Stainless steel

Shell
3 = 316 Stainless steel

Bladder Compound

Compound	Oper. Temp Range	Typical Fluids
NBR	5° to 180°F	mineral oils
3	32° to 180°F	water & water-glycols (5% minimum glycol)
4	-50° to 180°F	mineral oils
5	-20° to 250°F	mineral oils
6	-40° to 250°F	mineral oils (with low temperature CS shell)
7	-20° to 200°F	phosphate esters & brake fluids
FPM	5° to 300°F	chlorinated hydrocarbons

2 = NBR (Buna N)
3 = ECO (Hydrin)
4 = IIR (Butyl)
5 = LT-NBR (low temp. Buna)
6 = FPM (Fluoroelastomer)
7 = Others (available on request)

Country of Installation
S1 = USA & Canada

Maximum Working Pressure (in bar)
82 = 1189 psi

Fluid Port Connection
Threaded
C = SAE
D = NPT
Flanged
E = SAE 2" - 3000 psi

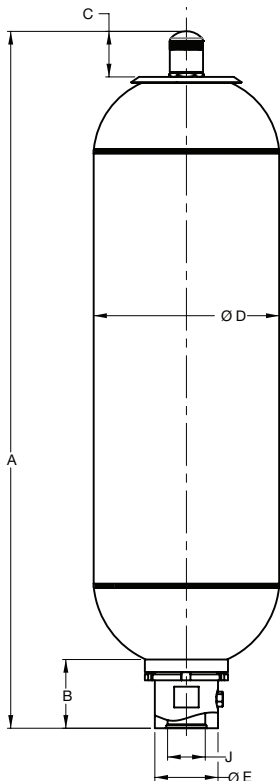

SB 90... (1190 psi)

Nom. Vol. (L)	Eff. Gas Vol. in ³ / (gal.)	Weight	A	B ⁽¹⁾	C	ØD	ØE	Thread J	
								SAE	NPTF
10	566	59 (31)	21.2 (538)	3.1 (80)	2.3 (58)	8.6 (219)	3.0 (76)	1 7/8-12 UN (SAE-24)	2"
20	1125	102 (46)	33.4 (848)	3.1 (80)	2.3 (58)	8.6 (219)	3.0 (76)	1 7/8-12 UN (SAE-24)	2"
35	2080	146 (66)	53.9 (1368)	3.1 (80)	2.3 (58)	8.6 (219)	3.0 (76)	1 7/8-12 UN (SAE-24)	2"
50	3205	212 (96)	77.9 (1978)	3.1 (80)	2.3 (58)	8.6 (219)	3.0 (76)	1 7/8-12 UN (SAE-24)	2"

Dimensions are in inches/(mm) and lbs/(kg)

Additional sizes available.

For sizes above 15 gal., contact HYDAC Accumulator Product Management.

ANSI Flange Adapters Available

- 300 lb. - sizes 1/2" & 3/4"
- 600 lb. - sizes 1/2" & 3/4"

Meets API Specifications

Model Code

Model Codes containing RED selections are non-standard items – Contact HYDAC for information and availability
 Not all combinations are available

SB 330 - 20 S 11 / 112 S - 210 C XXX

Series _____

- SB 330 = Bladder accumulator (3000 psi, Typically)
- SB 600 = Bladder accumulator (5000 psi, Typically)

Design _____

- (omit) = Standard (bottom repairable)
- TR = Top Repairable

Size (see dimension tables on the previous pages for most common sizes) _____

- 10 = 2.5 gallons
- 20 = 5 gallons
- 32 = 10 gallons
- 42 = 11 gallons
- 54 = 15 gallons

Line Connection _____

- S = Threaded (SAE Lock Nut)
- F = Flanged (SAE Lock Nut)

Gas Port _____

- 11 = 2 Piece Gas Valve (see pg 16 for details)

Material Code _____

Depending on Application

- 112 = Standard for oil service (mineral oil)

Fluid Port _____

- 0 = Synthetic coated carbon steel (PTFE solid film, internal & external for water service)
- 1 = Carbon steel
- 2 = High strength stainless steel (typically 17-4 PH)
- 3 = Stainless steel (corrosion resistance) (typically 316SS)
- 4 = Chemically plated carbon steel (internal & external for water service)
- 6 = Low temperature carbon steel (<-40°F, min)
- 7 = Others available on request

Shell _____

- 0 = Synthetic coated carbon steel (PTFE solid film, internal & external for water service)
- 1 = Carbon steel
- 2 = Chemically plated carbon steel (internal & external for water service)
- 6 = Low temperature carbon steel (<-40°F)
- 7 = Others available on request

Bladder Compound

Compound	Oper. Temp Range	Typical Fluids
2 = NBR (Buna N)	-10° to 220°F	mineral oils
3 = ECO (Hydrin)	-10° to 220°F	water & water-glycols (5% minimum glycol)
4 = IIR (Butyl)	-50° to 180°F	mineral oils
5 = LT-NBR (low temp. Buna)	-20° to 250°F	mineral oils
6 = FPM (Fluoroelastomer)	-40° to 250°F	mineral oils (with low temperature CS shell)
7 = Others (available on request)	-20° to 200°F	phosphate esters & brake fluids
	5° to 300°F	chlorinated hydrocarbons

Country of Installation _____

- S = USA
- W1 = ABS Type Approval
- W3 = DNV Type Approval
- S1 = Canada (CRN Registration)
- U = PED/CE

(for other countries see page 2 for proper code designation)

Maximum Working Pressure _____

- 210 = 3000 psi
- 345 = 5000 psi
- 414 = 6000 psi

Fluid Port Connection _____

Threaded _____

- C = SAE (ANSI B1.1)
- D = NPT (ANSI B1.2)

Flanged _____

- E = SAE 2" - 3000 psi (Code 61)
- F = SAE 1 1/2" - 6000 psi (Code 62)

Gas Precharge Pressure (P₀) in bar _____

- xxx = 3 digits

Note: For the full line of bladder accumulators please refer to page 8.

Bladder Accumulators SB Series Bottom Repairable

SB 330... (3000 psi)

Size (L)	Nom. Vol. (gal.)	Eff. Gas Vol. in ³ / (gal.)	Weight	A	B	C	ØD	ØE	Thread-J NPTF		Q ⁽¹⁾ gpm
10	2 1/2	566 (2.45)	86 (39)	22.0 (559)	3.1 (80)	2.3 (58)	9.1 (231)	3.0 (76)	1 1/4	2"	240
20	5	1125 (4.87)	140 (63)	34.5 (876)	3.1 (80)	2.3 (58)	9.1 (231)	3.0 (76)	1 1/4	2"	240
32	10	2080 (9.00)	226 (102)	54.7 (1390)	3.1 (80)	2.3 (58)	9.1 (231)	3.0 (76)	1 1/4	2"	240
42	11	2320 (10.04)	270 (123)	60.2 (1530)	3.1 (80)	2.3 (58)	9.1 (231)	3.0 (76)	1 1/4	2"	240
54	15	3205 (13.87)	330 (150)	78.3 (1990)	3.1 (80)	2.3 (58)	9.1 (231)	3.0 (76)	1 1/4	2"	240

See notes at bottom of page

Dimensions are for general information only, all critical dimensions should be verified.
Dimensions are in inches/(mm) and lbs/(kg)

SB 600... (5000 psi)

Size (L)	Nom. Vol. (gal.)	Eff. Gas Vol. in ³ / (gal.)	Weight	A	B	C	ØD	ØE	Thread-J NPTF		Q ⁽¹⁾ gpm
10	2 1/2	566 (2.45)	114 (52)	22.4 (568)	3.1 (80)	2.8 (70)	9.1-9.7 (232 -247)	3.0 (76)	1 1/4	2"	240
20	5	1125 (4.87)	162 (73)	35.0 (888)	3.1 (80)	2.8 (70)	9.1-9.7 (232-247)	3.0 (76)	1 1/4	2"	240
32	10	2080 (9.00)	250 (113)	55.2 (1402)	3.1 (80)	2.8 (70)	9.1-9.7 (232-247)	3.0 (76)	1 1/4	2"	240
54	15	3180 (13.77)	506 (230)	78.8 (2002)	3.1 (80)	2.8 (70)	9.1-9.7 (232-247)	3.0 (76)	1 1/4	2"	240

See notes at bottom of page

Dimensions are for general information only, all critical dimensions should be verified.
Dimensions are in inches/(mm) and lbs/(kg)

Split Flange Connections (sizes 10 - 54)

Series	B	øE	Split Flange Connection F	Q ⁽¹⁾ gpm
SB 330 SB 330 TR	4.1 (104)	2.8 (71.4)	SAE 2" - 3000 psi Code 61	240
SB 600 SB 600 TR	5.5 (140)	2.5 (63.5)	SAE 1 1/2" - 5000 psi Code 62	240

See notes at bottom of page

Dimensions are for general information only, all critical dimensions should be verified.
Dimensions are in inches/(mm) and lbs/(kg)

Note:

1) Maximum discharge flow rate recommended for vertically mounted accumulators.

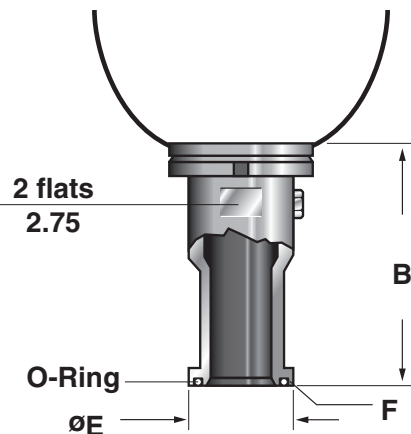
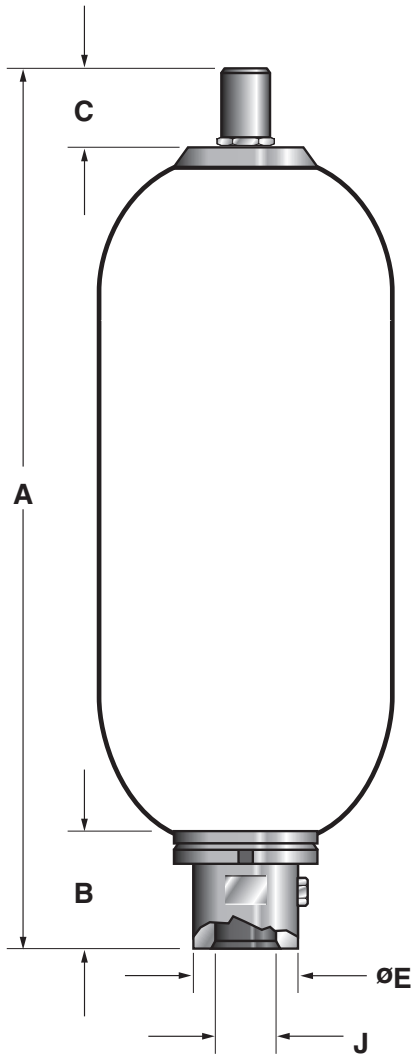

Top Repairable

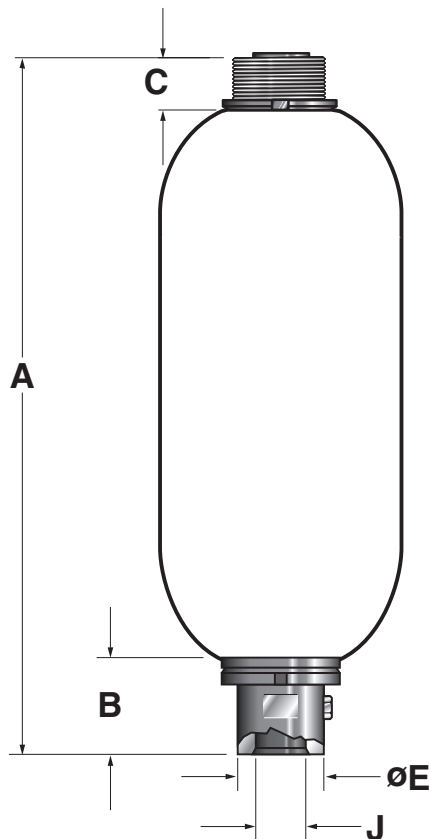

SB 330 TR... (3000 psi)

Size (L)	Nom. Vol. (gal.)	Eff. Gas Vol. in ³ / (gal.)	Weight	A	B	C	ØD	ØE	Thread-J NPTF		Q ⁽¹⁾ gpm
10	2 1/2	566 (2.45)	94 (43)	21.3 (540)	3.1 (80)	1.6 (40)	9.1 (231)	3.0 (76)	1 1/4	2"	240
20	5	1125 (4.87)	140 (63)	34.8 (883)	3.1 (80)	1.6 (40)	9.1 (231)	3.0 (76)	1 1/4	2"	240
32	10	2080 (9.00)	226 (102)	55.0 (1397)	3.1 (80)	1.6 (40)	9.1 (231)	3.0 (76)	1 1/4	2"	240
42	11	2320 (10.04)	270 (123)	60.2 (1530)	3.1 (80)	1.6 (40)	9.1 (231)	3.0 (76)	1 1/4	2"	240
54	15	3205 (13.87)	330 (150)	78.6 (1997)	3.1 (80)	1.6 (40)	9.1 (231)	3.0 (76)	1 1/4	2"	240

See note at bottom of page

Dimensions are for general information only, all critical dimensions should be verified.
Dimensions are in inches/(mm) and lbs/(kg)

SB 600 TR... (5000 psi)

Size (L)	Nom. Vol. (gal.)	Eff. Gas Vol. in ³ / (gal.)	Weight	A	B	C	ØD	ØE	Thread-J NPTF		Q ⁽¹⁾ gpm
10	2.5	566 (2.45)	126 (57)	20.9 (531)	3.1 (80)	1.6 (40)	9.1-9.7 (232 -247)	3.0 (76)	1 1/4	2"	240
20	5	1125 (4.87)	172 (78)	33.5 (851)	3.1 (80)	1.6 (40)	9.1-9.7 (232 -247)	3.0 (76)	1 1/4	2"	240
32	10	2080 (9.00)	260 (118)	53.7 (1364)	3.1 (80)	1.6 (40)	9.1-9.7 (232-247)	3.0 (76)	1 1/4	2"	240
54	15	3205 (13.87)	506 (230)	77.3 (1964)	3.1 (80)	1.6 (40)	9.1-9.7 (232-247)	3.0 (76)	1 1/4	2"	240

See note at bottom of page

Dimensions are for general information only, all critical dimensions should be verified.
Dimensions are in inches/(mm) and lbs/(kg)

2 Piece Gas Valve

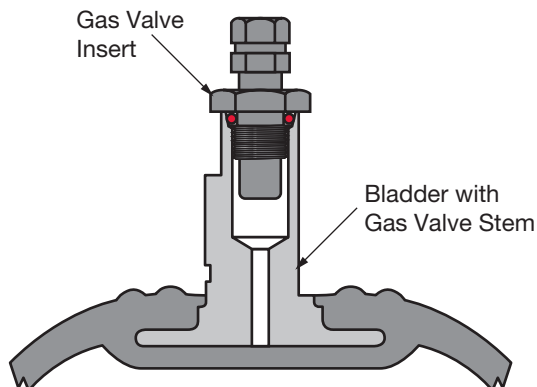

Note: Maximum discharge flow rate recommended for vertically mounted accumulators.

Bladder Accumulators - Spare Parts

Bottom Repairable SB330, SB330H, SB330N SB600, SB600N

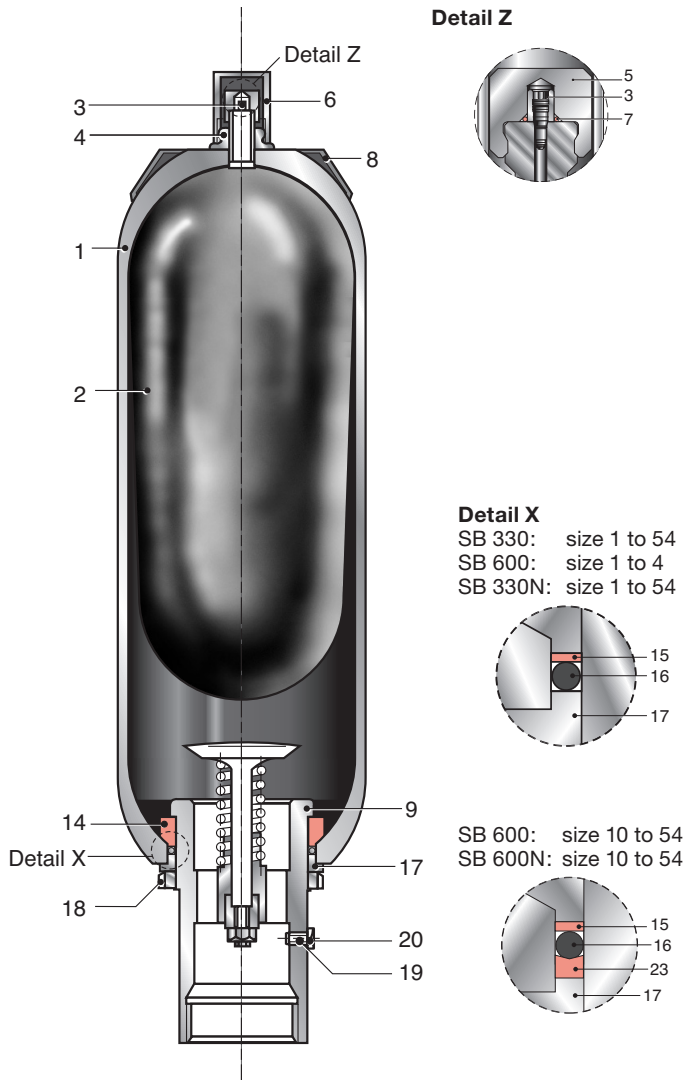

Repair Kits consist of items
2, 3, 4 (SB 600 only), 5, 7, 15, 16, 23 (where applicable)

Seal Kits consist of items
15, 16, 23 (where applicable)

Top Repairable SB330T, SB330HT, SB330TR, SB330NTR, SB 600T, SB600TR, SB600NTR

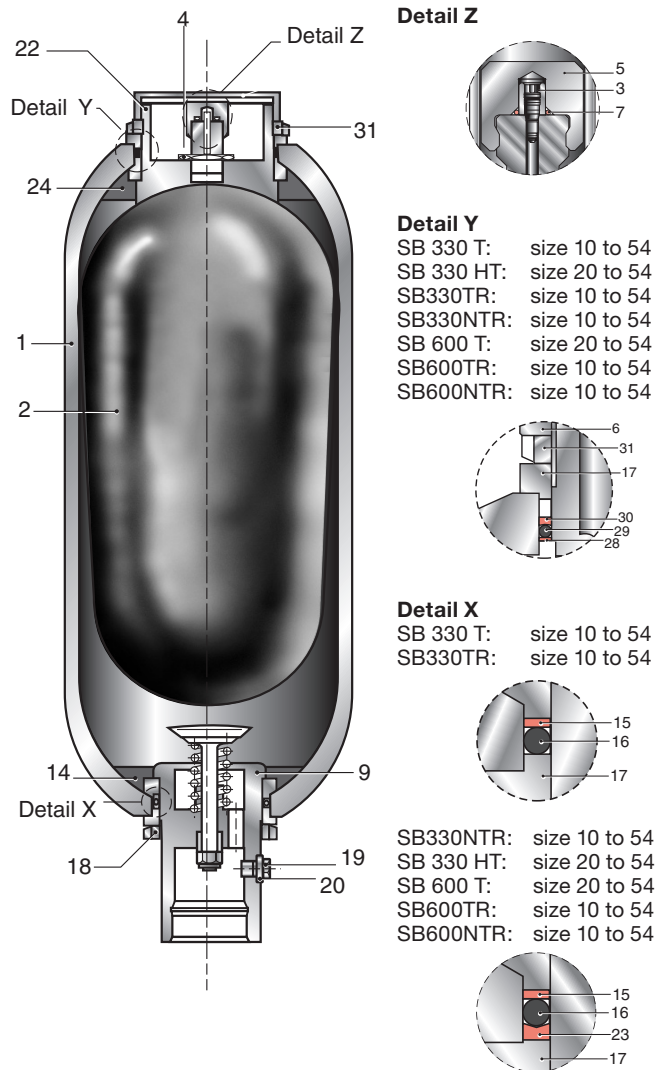

Repair Kits consist of items
SB330T, SB330TR, SB330NTR SB600T, SB600TR, SB600NTR:
2, 3, 5, 7, 15, 16, 23 (where applicable), 28, 29, 30

SB330HT: 2, 3, 5, 7, 23 (where applicable), 28, 29, 30

Seal Kits consist of items
15, 16, 23 (where applicable), 28, 29, 30

Parts Legend

Gas Side

- | | |
|------------------------|------------------------|
| 1 Shell | 8 Name Plate |
| 2 Bladder | 22 Gas Port Adapter |
| 3 Gas Valve Core | 24 Anti-extrusion Ring |
| 4 Gas Side Lock Nut | 28 Flat Ring |
| 5 Valve Seal Cap | 29 O-ring |
| 6 Valve Protection Cap | 30 Back-up Ring |
| 7 O-ring | 31 Gas Port Lock Nut |

Fluid Side

- | |
|------------------------|
| 9 Fluid Port |
| 14 Anti-extrusion Ring |
| 15 Flat Ring |
| 16 O-ring |
| 17 Spacer Ring |
| 18 Fluid Port Lock Nut |
| 19 Vent Screw |
| 20 Seal Ring |
| 23 Back-up Ring |

Seal Kits

For seal kits and repair kits other than Buna N, and for sizes not listed please consult factory.

Bottom Repairable - Buna N*

Size	3000 PSI		5000 PSI	
	Fluid Port Seal Kit	Bladder Repair Kit	Fluid Port Seal Kit	Bladder Repair Kit
1 (1 qt.)	2054031	2054034	2054032	2054455
4 (1 gal.)	2054032	2054035	2054032	2054035
6 (1.5gal.)	2054032	2054677	N/A	N/A
10 (2.5 gal.)	2054033	2054036	2054283	2054279
20 (5 gal.)	2054033	2054037	2054283	2054280
32 (10 gal.)	2054033	2054038	2054283	2054281
42 (11 gal.)	2054033	2075963	N/A	N/A
54 (15 gal.)	2054033	2054039	2054283	2054282

*For seal kits and repair kits other than Buna N, and for sizes and types not listed please contact HYDAC.

Tools

Item	Part Number
Pull Rod (Schrader Valve)	2092306
Pull Rod (G 1/4" valve)	2094570
Gas Valve Torque Wrench	2080987
Gas Valve Core Tool	0616886
Spanner Wrenches:	
1 Qt. - 52-55 mm	2054547
1-15 Gal - 68-100 mm	2054545
High Flow and Top Repairable 120-130 mm	2054548

Gas Valve Torque Wrench



Gas Valve Core Tool



Spanner Wrench



Pull Rod: Comes complete with fitting for gas valve, and 4 extension segments to accommodate accumulators up to 54 liter

WARNING: Only qualified persons should perform maintenance on any type of accumulator. Complete maintenance instructions are available - Contact HYDAC.

Competitive Crossover Bladder Accumulators

Standard Bottom Repairable 3000 PSI / Oil Service / Buna N / SAE Thread



Size	HYDAC	Accum Inc. ³	Bosch	Greer	Oil Air	Parker
1 qt	2054003	A1QT3100-3	0-531-112-640	851550	1QT-100-6	BA002B3T01A1
1 gal	2054004	A13100-3	0-531-113-640	841720	1-100-6	BA01B3T01A1
2.5 gal	2054005	A2.53100-3	0-531-114-640	849760	2.5-100-6	BA02B3T01A1
5 gal	2054006	A53100-3	0-531-115-640	849392	5-100-6	BA05B3T01A1
10 gal	2054007	A103100-3	0-531-115-650	850670	10-100-6	BA10B3T01A1
15 gal	2054008	A153100-3	0-531-116-6401	849910	15-100-6	BA15B3T01A1

Repair Kits¹⁰ Replacement Bladder

Size	HYDAC	Accum Inc. ³	Bosch ²	Greer	Oil Air	Parker
1 qt 5/8" Gas Valve	2054655	AI-1QT-3KT	N/A	7029283	A1QT-3003	08506930023
1 qt 7/8" Gas Valve (HYDAC standard)	2054034	AI-1QT-3KT	9-534-232-0243	702928	A1QT-300	N/A
1 gal	2054035	AI-1-3KT	9-534-232-025	702956	A1-300	0850693010
2.5 gal	2054036	AI-2.5-3KT	9-534-232-026	702970	A2.5-2-300	0850693025
5 gal	2054037	AI-5-3KT	9-534-232-027	702984	A5-2-300	0850693050
10 gal	2054038	AI-10-3KT	9-534-232-028	702998	A10-2-300	0850693100
15 gal	2054039	AI-15-3KT	9-534-232-0291	703026	A15-2-300	0850693150

Top Repairable 3000 PSI / Oil Service / Buna N / SAE Thread



Size	HYDAC	Accum Inc. ³	Bosch ⁵	Greer	Oil Air	Parker
2.5 gal	2089035	A2.5TR3100-3	9-530-230-075	851420	TR-2.5-100-6	BA02T3T01A1
5 gal	2081834	A5TR3100-3	9-530-230-085	851430	TR-5-100-6	BA05T3T01A1
10 gal	2079383	A10TR3100-3	9-530-230-095	851590	TR-10-100-6	BA10T3T01A1
15 gal	2079385	A15TR3100-3	9-530-230-1051	852480	TR-15-100-6	BA15T3T01A1

Repair Kits¹⁰ Replacement Bladder

Size	HYDAC	Accum Inc. ⁴	Bosch ^{2,4}	Greer	Oil Air	Parker
2.5 gal	2062823	AI-2.5-3KT	N/A	702970	A2.5-2-300	0850693025
5 gal	2054104	AI-5-3KT	9-534-232-027	702984	A5-2-300	0850693050
10 gal	2054105	AI-10-3KT	9-534-232-028	702998	A10-2-300	0850693100
15 gal	2054106	AI-15-3KT	9-534-232-0291	703026	A15-2-300	0850693150

Standard Bottom Repairable 5000 PSI / Oil Service / Buna N / SAE Thread



Size	HYDAC	Accum Inc. ³	Bosch ⁵	Greer	Oil Air	Parker
1 qt	2054188	N/A	N/A	851120	N/A	N/A
1 gal	2054189	N/A	N/A	851130	N/A	BA01B5T01A1
2.5 gal	2054276	A2.55100-3	N/A	851150	G-2.5-5-100-6	BA02B5T01A1
5 gal	2054275	A55100-3	N/A	855360	G-5-5-100-6	BA05B5T01A1
10 gal	2054277	A105100-3	N/A	850680	G-10-5-100-6	BA10B5T01A1
15 gal	2054278	A155100-3	N/A	855370	G-15-5-100-6	BA15B5T01A1

Repair Kits¹⁰ Replacement Bladder

Size	HYDAC	Accum Inc. ⁹	Bosch ^{2,4}	Greer	Oil Air	Parker
1 qt	2054455 ⁷	N/A	N/A	704040	N/A	N/A
1 gal	2054035 ⁷	N/A	N/A	704060	N/A	N/A
2.5 gal	2054279 ⁸	AI-2.5-5-3KT	N/A	704080	AG-2.5-5-300	08619050258
5 gal	2054280 ⁸	AI-5-5-3KT	N/A	704100	AG-5-5-300	08619050508
10 gal	2054281 ⁸	AI-10-5-3KT	N/A	704120	AG-10-5-300	08619051008
15 gal	2054282 ⁸	AI-15-5-3KT	N/A	704140	AG-15-5-300	08619051508

Footnotes

- 1 Only 14 gallon
- 2 Bladder only
- 3 Size of gas valve stem may be different than HYDAC standard (7/8"-14 UNF)
- 4 Style of gas valve stem (top-repairable) may differ (i.e. has flat) from HYDAC
- 5 Not ASME approved; TUV approved accumulators only
- 6 Top-repairable only
- 7 Gas valve stem 7/8"-14 UNF
- 8 Gas valve stem 2"
- 9 Size and/or style of gas valve may be different than HYDAC standard
- 10 HYDAC Repair Kit consists of:
 - Bladder
 - Lock Nut (SB 600 only)
 - Seal Kit
 - Gas Valve Core
 - Valve Seal Cap



Accumulators

SB 330 / 600 Bladder Accumulators

Service and Parts

Index

1. General

Bottom Repairable Bladder Accumulators

2. Spare Parts List
- 2.1 Torque Requirements
3. Maintenance Instructions
- 3.1 Disassembly
- 3.2 Inspection Of Components
- 3.3 Assembly

Top Repairable Bladder Accumulators

4. Spare Parts List
- 4.1 Torque Requirements
5. Maintenance Instructions
- 5.1 Disassembly
- 5.2 Inspection Of Components
- 5.3 Assembly

To safeguard against a potential source of danger which can occur in bladder and diaphragm accumulators, we would like to draw your attention to the following information.

Please note that this should be taken into account when carrying out any work on systems with hydraulic accumulators.



CAUTION!

After discharging and/or completely draining the accumulator (e.g. to depressurize the hydraulic system before work is carried out), the accumulator can build-up an amount of pressure again when the lines are later shut off on the fluid side.

This problem must be taken into account generally and in particular before carrying out work on hydraulic systems which include connected hydraulic accumulators.

All the fluid-side lines connected to the accumulator must therefore be depressurized and after that the lines remain open. Only then may the appropriate work (e.g. disassembly of the accumulator) be carried out.

WARNING!

Hydraulic accumulators are pressurized vessels and only qualified technicians should perform repairs. Never weld, braze or perform any type of mechanical work on the accumulator shell. Always drain the fluid completely from the accumulator before performing any work, such as recommended repairs or connecting pressure gauges.

Special Tools Required:

1. HYDAC Charging and Gauging Unit:
 - For bottom repairable bladder accumulators: FPS or FPK with adapter FPK/SB may be used.
 - For top repairable bladder accumulators only the FPK with adapter FPK/SB may be used.
2. Gas Valve Core Tool
3. Spanner Wrench(es)
4. Bladder Pull Rod
5. Sockets 27mm / 32mm (*top repairable only*) / 36 mm
6. Blunt Flathead Screwdriver (*with rounded edges*)

NOTE: Additional standard tools are required including but not limited to: Soft Faced Hammer / Sockets / Torque Wrenches

Refer to additional information contained in the "Operating and Installation Instructions for HYDAC Accumulators".

The instructions included in this brochure cover Bottom Repairable and Top Repairable Bladder Accumulators.

Before servicing a bladder accumulator obtain the appropriate HYDAC repair kit. Use only original HYDAC replacement parts.

Read all instructions thoroughly before beginning any type of service or repair work.



CAUTION!

PRESSURIZED VESSEL USE DRY NITROGEN GAS ONLY

Please refer to HYDAC Operating and Installation Instructions

NOTE: All details subject to technical modification

2. Replacement Parts Drawing: SB330, SB330H, SB330N, SB600, SB600N

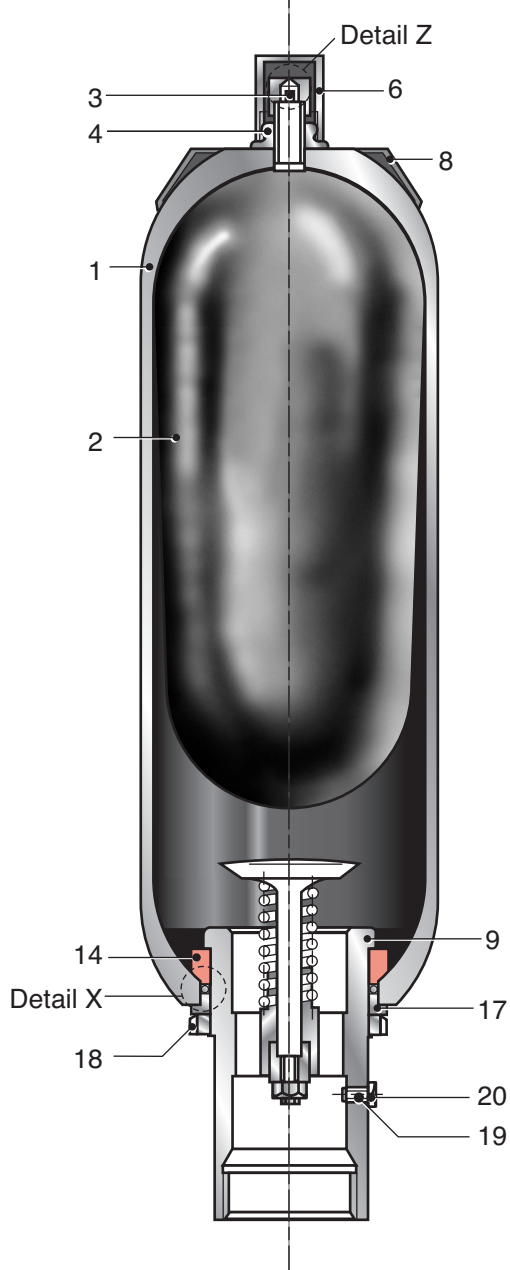

Detail Z

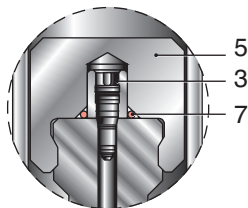

Detail X

SB 330: size 1 to 54
SB 600: size 1 to 4
SB 330N: size 1 to 54

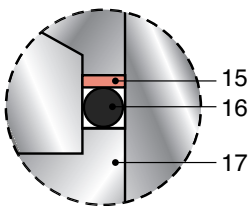

SB 600: size 10 to 54
SB 600N: size 10 to 54

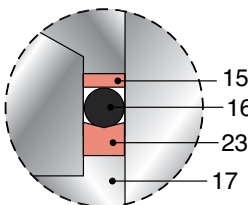

- | Item | Description: |
|------|-----------------------|
| 1 | Shell |
| 2 | Bladder |
| 3 | Gas Valve Core |
| 4 | Bladder Stem Lock Nut |
| 5 | Valve Seal Cap |
| 6 | Valve Protection Cap |
| 7 | O-ring |
| 8 | Name Plate |
| 9 | Fluid Port |
| 14 | Anti-extrusion Ring |
| 15 | Flat Ring |
| 16 | O-ring |
| 17 | Spacer Ring |
| 18 | Fluid Port Lock Nut |
| 19 | Fluid Port Vent Screw |
| 20 | Seal Ring |
| 23 | Back-up Ring |

Repair Kit Consists Of:

- | | |
|----|--|
| 2 | Bladder |
| 3 | Gas Valve Core |
| 4 | Bladder Stem Lock Nut
(SB 600 only) |
| 5 | Valve Seal Cap |
| 7 | O-Ring |
| 15 | Flat Ring |
| 16 | O-Ring |
| 23 | Back-up Ring
(where applicable) |

2.1 Torque Requirements:

Bottom Repairable Bladder Accumulators in Nm (lb-ft)

Part Name	SB 330			SB 330 H	SB 600	
	1	4 to 6	10 to 54	10 to 20	1 to 4	10 to 54
Gas Valve Core	0.5 (0.4)	0.5 (0.4)	0.5 (0.4)	0.5 (0.4)	0.5 (0.4)	0.5 (0.4)
Bladder Stem Lock Nut	80 (59)	80 (59)	80 (59)	80 (59)	80 (59)	150 (111)
Valve Seal Cap	30 (22)	30 (22)	30 (22)	30 (22)	30 (22)	30 (22)
Fluid Port Lock Nut	90 (66)	200 (148)	440 (325)	600 (443)	200 (148)	440 (325)
Vent Screw ¹⁾	4 (3)	22 (16)	30 (22)	30 (22)	22 (16)	30 (22)

1) For SAE threads only. For other thread types, consult HYDAC.

3. Bottom Repairable Bladder Accumulators

3.1 Disassembly

A After removal from the system, place the accumulator in a vice or secure it to a workbench. Remove **valve protection cap** (item 6) and unscrew **valve seal cap** (item 5). Attach the proper HYDAC Charging and Gauging Unit and completely relieve the gas precharge (refer to HYDAC Charging and Gauging brochure #02068202).

Remove **gas valve core** (item 3) by using the gas valve core tool.

B Unscrew **vent screw** (item 19) and remove **seal ring** (item 20).

Unscrew **lock nut** (item 18) by using spanner wrench. Remove **spacer ring** (item 17). If necessary, tap spacer ring with a plastic hammer to loosen.

C Loosen **fluid port** (item 9) and push it into the shell. Remove **back-up ring**, (item 23) where applicable, **O-ring** (item 16) and **flat ring** (item 15) from fluid port.

D Pull **anti-extrusion ring** (item 14) off fluid port and remove it through fluid side opening by folding it in half.

E Remove **fluid port** (item 9).

F Remove **bladder stem lock nut** (item 4) and **name plate** (item 8) from the gas side. Remove **bladder** (item 2) from fluid side. It may be necessary to fold the bladder lengthwise to remove it.

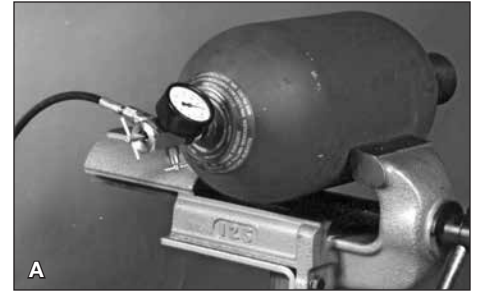

3.2 Inspection of Components

Shell:

- inside to ensure it is free of debris, rough spots, or chafe marks.
- fluid side bore for damage which could hamper proper sealing.
- exterior for any sign of damage.

If any interior or exterior damage is found, contact HYDAC for proper repair or replacement instructions.

Bladder:

The bladder must be checked for leakage. Reinstall gas valve core (item 3) and charge the bladder with nitrogen or compressed air to its natural shape and inspect for leakage.

If leakage occurs, first check the gas valve core (item 3) and replace it if necessary. If leakage still occurs, then the bladder must be replaced. The bladder must be visually inspected for lateral grooves and deep chafe marks. If any are found, the bladder should be replaced. Shallow chafe marks are insignificant and will not hamper performance.

Note: Bladders can not be repaired or revulcanized!

Fluid Port:

Depress poppet and rotate 90° to ensure free movement. Visually inspect poppet, threads, and sealing surfaces for any damage. If any damage is found, the fluid port should be replaced.

Vulcanized Anti-extrusion Ring:

Visually check vulcanized area between steel and rubber to make sure it is undamaged and that adhesion is still good (no gaps between rubber and metal). If the adhesion is poor or the rubber is cracked or shows signs of embrittlement or aging, replace anti-extrusion ring. Also check the seat area on the steel parts for grooves or any other damage. If any are found replace anti-extrusion ring.

Non-Vulcanized Anti-extrusion Ring:

Visually inspect area between the steel and rubber to make sure that the steel ring is properly seated. If the rubber is cracked or shows signs of embrittlement or aging, replace anti-extrusion ring. Also check the seat area on the steel parts for grooves or any other damage. If any are found replace anti-extrusion ring.

Seals:

New seals should always be used whenever reassembling any bladder accumulator.

Other Parts:

Inspect for damage and replace if necessary.

3.3 Assembly:

The interior of the shell must be absolutely free of any contamination or debris prior to assembly.

Prepare bladder for installation by removing **valve seal cap** (item 5), and **gas valve core** (item 3). Press all residual air out of bladder.

G Lubricate interior of shell and exterior of bladder with appropriate filtered fluid, using a fluid volume of approximately 10% of total accumulator volume.

(Do not use water, it is not a lubricant).

Different bladder compounds require different lubricants.

H Place **bladder stem lock nut** (item 4) over the pull rod with the male threads facing the pull rod handle. Insert bladder pull rod through shell (threaded connection toward fluid side opening).

Thread pull rod onto gas valve. Fold bladder in half lengthwise, then again if necessary. Pull the pull rod until gas valve emerges through gas port opening. Make sure bladder is stretched and not twisted when being inserted. Once gas valve is through opening, loosely attach **bladder stem lock nut** (item 4) to prevent bladder from slipping back into shell. Remove pull rod from gas valve.

Insert **gas valve core** (item 3) and torque to 0.5 Nm (0.4 lb-ft).

I To prevent damage to the threads and O-ring, tape fluid port threads before assembly. Insert fluid port into shell. Make sure bladder is fully extended within the shell.

J Fold **anti-extrusion ring** (item 14) in half and insert into shell with steel seat facing fluid side opening. To do this, push fluid port further into shell and then pull it back through the middle of the anti-extrusion ring.

K Slightly pull on the fluid port to position it. Do not allow fluid port to fall back into shell. This can be accomplished by either pulling on the fluid port while inserting seals or precharging the bladder with 10 to 15 psi of dry nitrogen to keep fluid port in position (refer to HYDAC Charging and Gauging brochure #02068202).

L Order of Assembly:

flat ring	item 15
O-Ring	item 16
back-up ring (where applicable)	item 23
spacer ring	item 17
fluid port lock nut	item 18



- M** Insert **flat ring** (*item 15*) into space between fluid port and shell. If it does not slide on properly, recenter fluid port in opening. Next, insert O-ring by pressing with a blunt flathead screwdriver (*with rounded edges*) at 90° intervals. Carefully, level O-ring onto seat. Where applicable insert **back-up ring** (*item 23*) over O-ring with grooved surface toward O-ring.
- N** Remove protective tape from fluid port threads. Insert **spacer ring** (*item 17*) with “lip” placed in the shell. Thread on **fluid port lock nut** (*item 18*) and torque with spanner wrench*. Place **seal ring** (*item 20*) on **vent screw** (*item 19*) install in fluid port and torque*.
- O** On gas side, remove loosely attached **bladder stem lock nut** (*item 4*) and position **name plate** (*item 8*). Reapply **bladder stem lock nut** (*item 4*) and torque*.
- P** Attach appropriate HYDAC Charging and Gauging Unit and apply proper gas precharge (refer to HYDAC Charging and Gauging brochure #02068202). Check **bladder stem lock nut** (*item 4*) torque*.
- Q** Screw on **valve seal cap** (*item 5*) and torque*. Replace **valve protection cap** (*item 6*).

*refer to torque table in section 2.1

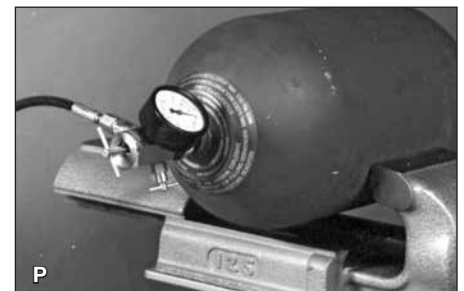

4. Replacement Parts Drawing: SB330T, SB330HT, SB330TR, SB330NTR, SB 600T, SB600TR, SB600NTR

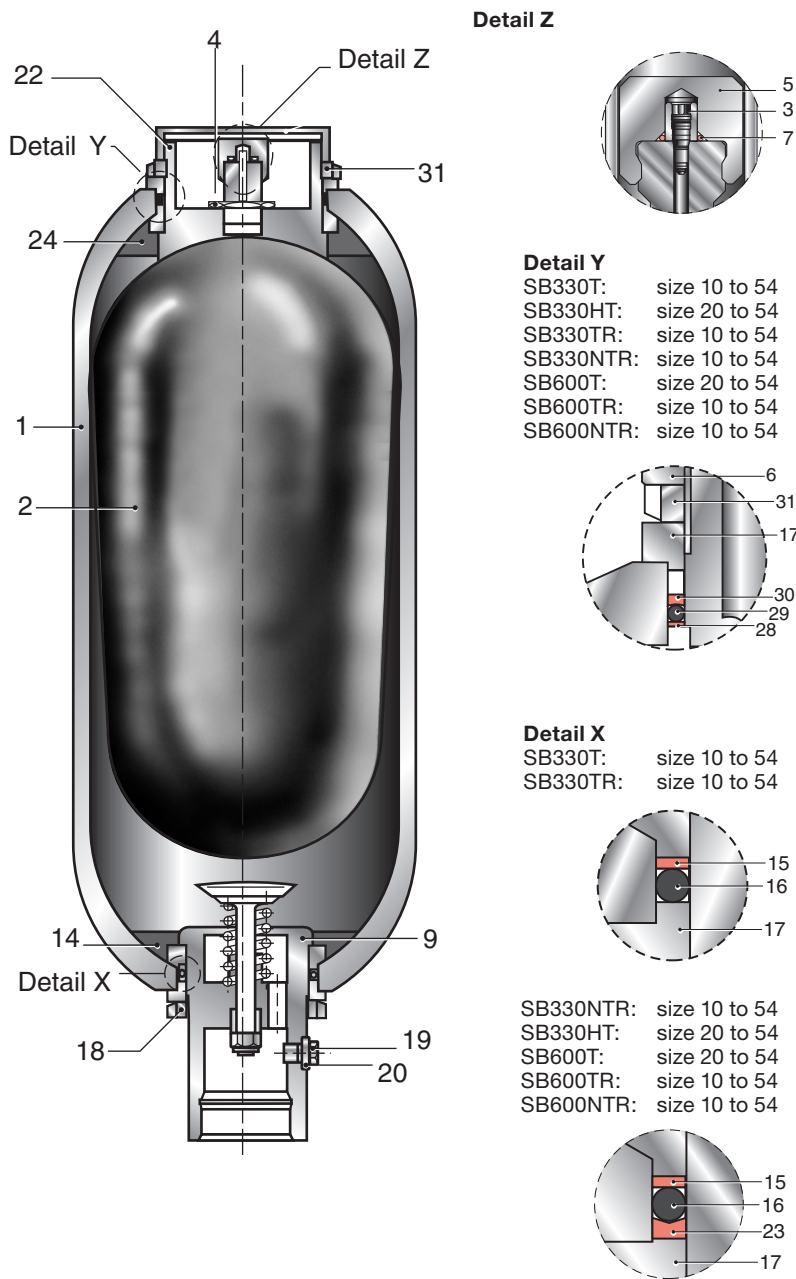

Detail Z

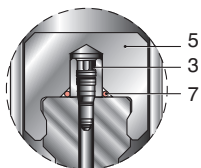

Detail Y

SB330T: size 10 to 54
 SB330HT: size 20 to 54
 SB330TR: size 10 to 54
 SB330NTR: size 10 to 54
 SB600T: size 20 to 54
 SB600TR: size 10 to 54
 SB600NTR: size 10 to 54

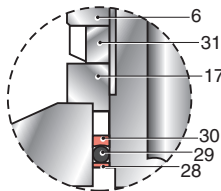

Detail X

SB330T: size 10 to 54
 SB330TR: size 10 to 54

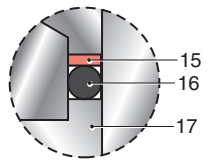

SB330NTR: size 10 to 54
 SB330HT: size 20 to 54
 SB600T: size 20 to 54
 SB600TR: size 10 to 54
 SB600NTR: size 10 to 54

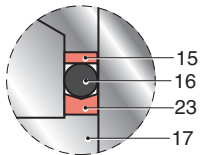

- Item Description:**
- 1 Shell
 - 2 Bladder
 - 3 Gas Valve Core
 - 4 Bladder Stem Lock Nut
 - 5 Valve Seal Cap
 - 6 Valve Protection Cap
 - 7 O-ring

- Fluid Side**
- 9 Fluid Port
 - 14 Anti-extrusion Ring
 - 15 Flat Ring
 - 16 O-ring
 - 17 Spacer Ring
 - 18 Fluid Port Lock Nut
 - 19 Vent Screw
 - 20 Seal Ring
 - 23 Back-up Ring

- Gas Side**
- 22 Gas Port Adapter
 - 24 Anti-extrusion Ring
 - 28 Flat Ring
 - 29 O-ring
 - 30 Back-up Ring
 - 31 Gas Port Lock Nut

**SB330T, SB330TR, SB330NTR, SB600T,
SB600TR, SB600NTR
Repair Kit consists of:**

- 2 Bladder
- 3 Gas Valve Core
- 5 Valve Seal Cap
- 7 O-ring
- 15 Flat Ring
- 16 O-ring
- 23 Back-up Ring (where applicable)
- 28 Flat Ring
- 29 O-ring
- 30 Back-up Ring

**SB330HT
Repair Kit consists of:**

- 2 Bladder
- 3 Gas Valve Core
- 5 Valve Seal Cap
- 7 O-ring
- 23 Back-up Ring (where applicable)
- 28 Flat Ring
- 29 O-ring
- 30 Back-up Ring

4.1 Torque Requirements:

Top Repairable Bladder Accumulators in Nm (lb-ft)

Part Name	SB 330 H 20 to 54	SB 330 T 10 to 54	SB 330 TR 10 to 54	SB 600 T 20 to 54	SB 600 TR 10 to 54
Gas Valve Core	0.5 (0.4)	0.5 (0.4)	0.5 (0.4)	0.5 (0.4)	0.5 (0.4)
Bladder Stem Lock Nut	80 (59)	80 (59)	80 (59)	80 (59)	80 (59)
Valve Seal Cap	30 (22)	30 (22)	30 (22)	30 (22)	30 (22)
Fluid Port Lock Nut	600 (443)	440 (325)	440 (325)	440 (325)	440 (325)
Vent Screw ³⁾	30 (22)	30 (22)	30 (22)	30 (22)	30 (22)
Gas Port Lock Nut	600 (443)	600 (443)	440 (325)	440 (325)	30 (22)

3) For SAE threads only. For other thread types, consult HYDAC.

5. Top Repairable Bladder Accumulators

Top repairable accumulators may also be repaired from the bottom (*fluid*) side. For this procedure please see section 3.

5.1 Disassembly

A Relieve system fluid pressure and drain all fluid from accumulator.

Remove **valve protection cap** (*item 6*) (if applicable) and unscrew **valve seal cap** (*item 5*). Attach proper HYDAC Charging and Gauging Unit (*FPK with adapter FPK/SB*) and completely relieve the gas precharge pressure (refer to *HYDAC Charging and Gauging brochure #02068202*).

B Remove **gas valve core** (*item 3*) by using the gas valve core tool. Thread pull rod onto gas valve and hold to keep gas port from falling into shell.

C Unscrew **gas port lock nut** (*item 31*) using spanner wrench. Remove **spacer ring** (*item 17*). If necessary, tap spacer ring with a plastic hammer to loosen. Push gas port adapter into shell.

D Remove **back-up ring** (*item 30*), **O-ring** (*item 29*), and **flat ring** (*item 28*) before removing anti-extrusion ring. Remove **anti-extrusion ring** (*item 24*) from gas port adapter, then fold it in half to pull it through the gas side opening.

E Pull gas port adapter through gas side opening and grasp the gas port adapter with one hand, while removing the pull rod with the other.

Remove the **gas port/bladder assembly** (*item 22 and 2*) from the shell. It may be necessary to fold the bladder lengthwise to remove it.

F Remove **bladder stem lock nut** (*item 4*) from gas valve and separate **gas port adapter** (*item 22*) from **bladder** (*item 2*).



5.2 Inspection of Components

Shell:

- inside to ensure it is free of debris, rough spots, or chafe marks.
- fluid side and gas side bores for damage which could hamper proper sealing.
- exterior for any sign of damage.

If any interior or exterior damage is found, contact HYDAC for proper repair or replacement instructions.

Bladder:

The bladder must be checked for leakage. Reinstall gas valve core (*item 3*) and charge the bladder with nitrogen or compressed air to its natural shape and inspect for leakage.

If leakage occurs, first check the gas valve core (*item 3*) and replace it if necessary. If leakage still occurs, then the bladder must be replaced. The bladder must be visually inspected for lateral grooves and deep chafe marks. If any are found, the bladder should be replaced. Shallow chafe marks are insignificant and will not hamper performance.

Note: Bladders can not be repaired or revulcanized.

Fluid Port:

Depress poppet and rotate 90° to ensure free movement. Visually inspect poppet, threads, and sealing surfaces for any damage. If any damage is found, the fluid port should be replaced.

Vulcanized Anti-extrusion Ring:

Visually check vulcanized area between steel and rubber to make sure it is undamaged and that adhesion is still good (*no gaps between rubber and metal*). If the adhesion is poor or the rubber is cracked or shows signs of embrittlement or aging, replace anti-extrusion ring. Also check the seat area on the steel parts for grooves or any other damage. If any are found replace anti-extrusion ring.

Non-Vulcanized Anti-extrusion Ring:

Visually inspect area between the steel and rubber to make sure that the steel ring is properly seated. If the rubber is cracked or shows signs of embrittlement or aging, replace anti-extrusion ring. Also check the seat area on the steel parts for grooves or any other damage. If any are found replace anti-extrusion ring.

Gas Porter Adapter:

Visually inspect the threads and sealing surfaces of the gas port adapter for signs of damage. If any damage is found, the gas port adapter should be replaced.

Seals:

New seals should always be used whenever reassembling any bladder accumulator.

Other Parts:

Inspect for damage and replace if necessary.

5.3 Assembly

The interior of the shell must be absolutely free of any contamination or debris prior to assembly.

Prepare bladder for installation by removing **valve seal cap** (item 5), and **gas valve core** (item 3). Purge all residual air.

Lubricate interior of shell and exterior of bladder with appropriate filtered fluid, using a fluid volume of approximately 10% of total accumulator volume.

(Do not use water, it is not a lubricant).

Different bladder compounds require different lubricants.

G Attach **gas port adapter** (item 22) to bladder with gas valve protruding through adapter opening. Loosely screw **bladder stem lock nut** (item 4) onto gas valve to keep gas port and bladder connected.

H Fold **bladder** (item 2) in half lengthwise and insert through gas side opening. Make sure bladder is stretched and not twisted when being inserted. Thread pull rod onto gas valve to position gas port adapter.

I Place the **anti-extrusion ring** (item 24) over the pull rod with the steel parts facing upward. Fold **anti-extrusion ring** (item 24) in half and insert into shell. To do this, push gas port adapter further into shell and then pull it back through anti-extrusion ring. Slide **gas port lock nut** (item 31) over and pull rod with beveled surface facing away from shell; loosely thread the gas port lock nut onto the gas port adapter. Remove pull rod from gas valve.

J Insert **gas valve core** (item 3) and torque to 0.5 Nm (0.4 lb-ft). Precharge bladder with 10 to 15 psi of dry nitrogen to hold **gas port adapter** (item 22) in place while completing assembly.

K Remove **gas port lock nut** (item 31). Insert **flat ring** (item 28) into space between gas port and shell. If it does not slide on properly, re-center gas port in opening. Next, insert **O-ring** (item 29) by pressing with a blunt flathead screwdriver (with rounded edges) at 90° intervals. Carefully, level O-ring onto seat. Insert **back-up ring** (item 30) over O-ring with grooved surface toward O-ring.

L Install **spacer ring** (item 17). Thread on **gas port lock nut** (item 31) with beveled surface facing away from shell and torque with spanner wrench*. Torque* **bladder stem lock nut** (item 4).

M Attach HYDAC Charging and Gauging Unit (FPK with adapter FPK/SB) and apply proper gas precharge pressure (refer to HYDAC Charging and Gauging brochure #02068202). Check **bladder stem lock nut** (item 4) torque².

N Screw on **valve seal cap** (item 5) and torque*. Replace **valve protection cap** (item 6) (if applicable).

*refer to torque table in section 4.1.

